

Farm Power and Machinery



Farm Power and Machinery

ICAR e-Course
For
B.Sc (Agriculture) and B.Tech (Agriculture)



Course Outlines

Lecture 01: Farm Power in INDIA – Human, Animal, Mechanical and Electrical Energy Sources and their Use in Agriculture

Lecture 02: Two Stroke and Four Stroke Engines, Working Principles, Applications- Types, Power and Efficiency

Lecture 03: Different Systems of IC Engine- Cooling, Lubricating, Fuel Injection Systems

Lecture 04: Tractors- Types and Utilities

Lecture 05: Tillage- Objectives and Types Furrow terminology and Methods of Ploughing. Field Capacity and Field Efficiency

Lecture 06: Primary Tillage- Objectives, Mouldboard Plough, Disc Plough, Chisel Plough, Subsoiler, Components and Functions, Types, Advantages and Disadvantages

Lecture 07: Secondary Tillage Equipment- Harrows, Land Forming Equipment-Rotavators- Wetland Equipment – Puddlers and Manure Trampers - cage wheels

Lecture 08: Sowing method- Seeds Drills, Seed Cum Fertilizer Drills- Components and Functions

Lecture 09: Paddy Transplanters, Types, Working Principle, Field and Nursery Requirements

Lecture 10: Implements for Intercultural Operations- Hoes, Long Handles Weeders, Cultivators and Rotary Tillage

Lecture 11: Sprayers and their Functions, Classification, Manually Operated Sprayers, Power Sprayers-Dusters, Types and Uses Sprayers

Lecture 12: Harvesting Tools and Equipment- sickles, Paddy Reapers and Combine- Harvesting Machinery for Groundnut, Tuber Crops-Sugarcane Harvesters

Lecture 14: Equipment for Land Development and soil conservation- Dozers, Levelers, Chisel plough, Sub Soil Plough, Blade Harrow, Bund Former Land Leveling

Lecture 13: Tools for Horticultural Crops- Propagation Tools, Planters and Harvesting Tools and Machinery

Lecture 15: Cost of Operation of Farm Machinery- Problem Solving

Lecture 16: Tractor and implement selection for different Agricultural Operations

Lecture 01

FARM POWER IN INDIA - HUMAN, ANIMAL, MECHANICAL AND ELECTRICAL ENERGY SOURCES AND THEIR USE IN AGRICULTURE

Farm Power is an essential input in agriculture for timely field operations for increasing production and productivity of land. Farm power is used for operating different types of machinery like tillage, planting, plant protection, harvesting and threshing machinery and other stationary jobs like operating irrigation equipment, threshers/ shellers / cleaners/ graders, etc.

SOURCES OF FARM POWER

There are different sources of farm power available in India which are classified as

1. Human power
2. Animal power
3. Mechanical power (Tractors + Power tillers + Oil engines)
4. Electrical power
5. Renewable energy (Biogas + Solar energy + Wind energy)

HUMAN POWER

Human power is the main source for operating small implements and tools at the farm. Stationary work like chaff cutting, lifting, water, threshing, winnowing etc are also done by manual labour. An average man can develop maximum power of about 0.1 hp for doing farm work.



Paddy Nursery collection



Nursery transport



Paddy transplanting



weeding



weeding



Winnowing

ANIMAL POWER

Power developed by an average pair of bullocks about 1 hp for usual farm work. Bullocks are employed for all types farm work in all seasons. Besides bullocks, other animals like camels, buffaloes, horses, donkeys, mules and elephants are also used at some places. The average force a draft animal can exert is nearly one-tenth of its body weight.



Ploughing a land



Ploughing a land



Bullock cart



Persian wheel- water lifting

MECHANICAL POWER

Broadly speaking, mechanical power includes stationary oil engines, tractors, power tillers and self propelled combines. Internal combustion engine is a good device for converting liquid fuel into useful work (mechanical work). These engines are two types

1. Spark ignition engines (Petrol or Kerosene engine)
2. Compression ignition engines (Diesel engines)

The thermal efficiency of diesel engine varies from 32 to 38 per cent whereas that of petrol engine varies from 25 to 32 per cent.

In modern days, almost all the tractors and power tillers are operated by diesel engines. Diesel engines are used for operating irrigation pumps, flour mills, oil ghanis, cotton gins, chaff cutter, sugarcane crusher, threshers, winnowers etc.



Two stroke engine

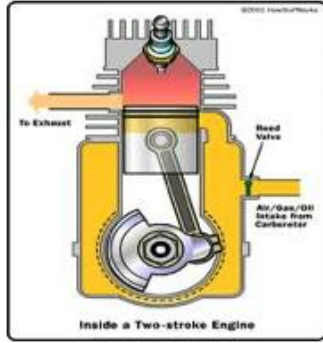

Two stroke engine
(SI engine)



Eighteen cylinder
two stroke engine



Four stroke Engine +
Pump



Thresher Thresher



Different types of tractors



Tractor with dozer blade



Power tiller



Power tillers

ELECTRICAL POWER

Electrical power is used mostly in the form of electrical motors on the farms. Motor is a very useful machine for farmers. It is clean, quiet and smooth running. Its maintenance and operation needs less attention and care. The operating cost remains almost constant throughout its life. Electrical power is used for water pumping, dairy industry, cold storage, farm product processing, fruit industry and many similar things.



Electric motors

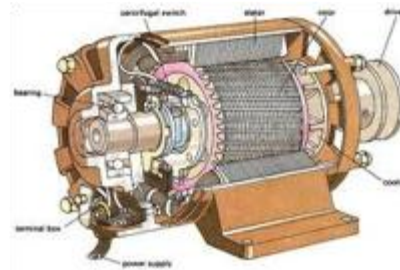
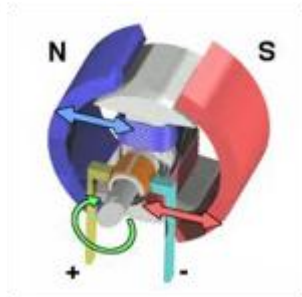

Electric motors



Electric motor + pump



Chaff cutter - motor driven

RENEWABLE ENERGY

It is the energy mainly obtained from renewable sources of energy like sun, wind, biomass etc. Biogas energy, wind energy and solar energy are used in agriculture and domestic purposes with suitable devices. Renewable energy can be used for lighting, cooking, water heating, space heating, water distillation, food processing, water pumping, and electric generation. This type of energy is inexhaustible in nature.

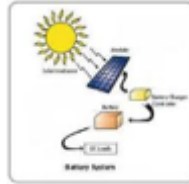
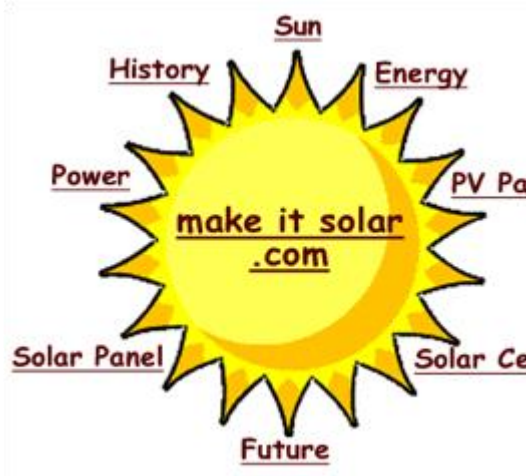

Different applications of solar energy



Solar electric panel Solar electric panel

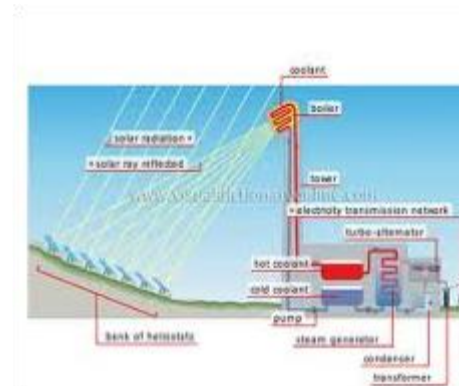

Grid connected solar energy



Wind Farms

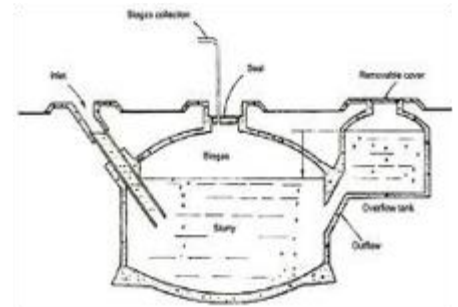

Biogas plants

Usage of renewable energy sources

Solar energy- Solar dryers, lantern, cooker, solar still, solar refrigeration, solar lighting etc

Wind energy- Water pumping, electricity generation etc.

Biomass energy- Gasifiers to produce producer gas, pyrolysis to produce liquid fuels, Biogas etc

Tidal energy - electricity generation

Geothermal energy- Heat and electricity production

MERITS AND DEMERITS DIFFERENT FARM POWER SOUECES

Merit	Demerit
Human Power	
1. Easily available.	1. Costliest power compared to all other forms of power.
2. Used for all types of work.	2. Very low efficiency.
	3. Requires full maintenance when not in use.
	4. Affected by weather condition and seasons.
Animal Power	
1. Easily available.	1. Not very efficient.
2. Used for all types of work.	2. Seasons and weather affect the efficiency.
3. Low initial investment.	3. Cannot work at a stretch.
4. Supplies manures to the field and fuels to farmers.	4. Requires full maintenance when not in use.
5. Lives on farm products.	5. Creates unhealthy and dirty atmosphere near the residence.
	6. Very slow in doing work.
Mechanical Power	
1. Efficiency is high.	1. Initial capital investment high.
2. Not affected by weather.	2. Fuel is costly.
3. Cannot run at a stretch.	3. Repairs and maintenance needs technical knowledge.
4. Requires less space.	
5. Cheaper form of power.	
Electrical Power	
1. Very cheap form of power.	1. Initial capital investment high.
2. High efficiency.	2. Requires good amount of technical knowledge.
3. Can work at a stretch.	3. If handled carelessly, it causes great danger.
4. Maintenance and operating cost is very low.	
5. Not affected by seasons.	

Concept of Farm Mechanization

The main concept of farm mechanization is to apply the principles of engineering and technology to do the agricultural operations in a better way to increase crop yield. This includes the development, application and management of all mechanical aids for field operation, water control, material handling, storage and processing. Mechanical aids include

hand tools, animal drawn implements, power tillers, tractors, engines, electric motors, grain processing and hauling equipments.

SCOPE OF FARM MECHANIZATION

Improved irrigation facilities, introduction of high yielding varieties. use of higher doses of fertilizers and pesticides have increased the scope for greater farm mechanization. Farm mechanization helps for proper utilization of basic inputs like water, seed and fertilizer, optimum placement of the seed and fertilizer, ploughing, removal of weeds, leveling of uneven land and land reclamation. If machines are used farmer and his animals are relieved of hard work. With the support of machines farmer can do his job better and quicker. He will get more leisure and devote his time to other works. He can earn better living.

BENEFITS OF FARM MECHANIZATION

1. Timeliness of operation
2. Precision of operation
3. Improvement of work environment.
4. Enhancement of safety
5. Reduction of drudgery of labour
6. Reduction of loss of crops and food products
7. Increased productivity of land
8. Increased economic return to farmer
9. Improved dignity of farmer
10. Progress and prosperity in rural areas

CONSTRAINTS IN FARM MECHANISATION (LIMITING FACTORS IN FARM MECHANIZATION)

1. Small land holdings
2. Less investing capacity of farmers
3. Adequate availability of draft animals
4. Lack of suitable farm machine for different operations
5. Lack of repair and servicing facilities for machines
6. Lack of trained man power
7. Lack of coordination between research organization and manufacturer
8. High cost of machines
9. Inadequate quality control of machine

QUESTIONS

1. The cheapest source of energy is -----
2. Power available from a farm labour is -----hp

3. Solar energy is a ----- energy
4. State the merits and demerits of different sources of energy used in farm



Lecture 02

TWO STROKE AND FOUR STROKE ENGINES, WORKING PRINCIPLES, APPLICATIONS - TYPES, POWER AND EFFICIENCY

Heat engine is a machine for converting heat, developed by burning fuel into useful work. It can be said that heat engine is equipment which generates thermal energy and transforms it into mechanical energy.

CLASSIFICATION OF HEAT ENGINES

1. Based on combustion of fuel:

(i) External combustion engine (ii) Internal combustion engine.

External combustion engine

Here, the working medium, the steam, is generated in a boiler, located outside the engine and allowed in to the cylinder to operate the piston to do mechanical work.

1. Internal combustion engine

In internal combustion engine, the combustion of fuel takes place inside the engine cylinder and heat is generated within the cylinder. This heat is added to the air inside the cylinder and thus the pressure of the air is increased tremendously. This high pressure air moves the piston which rotates the crank shaft and thus mechanical work is done

2. Based on fuel used

1. Diesel engine 2. Petrol engine 3. Gas engine

Diesel engine - Diesel is used as fuel

Petrol engine - Petrol is used as fuel

Gas engines - propane, butane or methane gases are used

3. Based ignition of fuel

1. Spark ignition engine (Carburetor type engines)
2. Compression ignition engine (injector type engines)

Spark ignition engine - a mixture of air and fuel is drawn in to the engine cylinder. Ignition of fuel is done by using a spark plug. The spark plug produces a spark and ignites the air- fuel mixture. Such combustion is called constant volume combustion (C.V.C.).

Compression ignition engine - In compression ignition engines air is compressed in to the

engine cylinder,. Due to this the temperature of the compressed air rises to 700-900 C. At this stage diesel is sprayed in to the cylinder in fine particles. Due to a very high temperature, the fuel gets ignited. This type of combustion is called constant pressure combustion (CP.C.) because the pressure inside the cylinder is almost constant when combustion is taking place.

4. Based on working cycle

1. **Four stroke cycle engine** - When the cycle is completed in two revolutions of the crankshaft, it is called four stroke cycle engine.
2. **Two stroke cycle engine.** - When the cycle is completed in one revolution of the crankshaft, it is called two stroke cycle engine

CONSTRUCTION OF AN IC ENGINE

I.C. engine converts the reciprocating motion of piston into rotary motion of the crankshaft by means of a connecting rod. The piston which reciprocating in the cylinder is very close fit in the cylinder. Rings are inserted in the circumferential grooves of the piston to prevent leakage of gases from sides of the piston. Usually a cylinder is bored in a cylinder block and a gasket, made of copper sheet or asbestos is inserted between the cylinder and the cylinder head to avoid ant leakage. The combustion space is provided at the top of the cylinder head where combustion takes place. The connecting rod connects the piston and the crankshaft. The end of the connecting rod connecting the piston is called small end. A pin called gudgeon pin or wrist pin is provided for connecting the piston and the connecting rod at the small end. . The other end of the connecting rod connecting the crank shaft is called big end. When piston is moved up and down, the motion is transmitted to the crank shaft by the connecting rod and the crank shaft makes rotary motion. The crankshaft rotates in main bearings which are fitted the crankcase. A flywheel is provided at one end of the crankshaft for smoothing the uneven torque produced by the engine. There is an oil sump at the bottom of the engine which contains lubricating oil for lubricating different parts of the engine.

WORKING PRINCIPLE OF I.C. ENGINE/ FOUR STROKE CYCLE ENGINE / TWO STROKE CYCLE ENGINE

A mixture of fuel with correct amount of air is exploded in an engine cylinder which is closed at one end. As a result of this explosion, heat is released and this heat causes the pressure of the burning gases to increase. This pressure forces a close fitting piston to move down the cylinder. The movement of piston is transmitted to a crankshaft by a connecting rod so that the crankshaft rotates and turns a flywheel connected to it. Power is taken from the rotating crank shaft to do mechanical work. To obtain continuous rotation of the crankshaft the explosion has to be repeated continuously. Before the explosion to take place, the used gases are expelled from the cylinder, fresh charge of fuel and air are admitted in to the cylinder and the piston moved back to its starting position. The sequences of events taking place in an engine is called the working cycle of the engine. The sequence of events taking place inside the engine are as follows

1. Admission of air or air-fuel mixture inside the engine cylinder (suction)
2. Compression of the air or air fuel mixture inside the engine (compression)
3. Injection of fuel in compressed air for ignition of the fuel or ignition of air-fuel mixture by an electric spark using a spark plug to produce thermal power inside the cylinder (power)
4. Removal of all the burnt gases from the cylinder to receive fresh charge (exhaust)

Note: Charge means admitting fresh air in to the cylinder in the case of compression ignition engines (diesel engines) or admitting a mixture of air and fuel in to the cylinder in the case of spark ignition engines.

FOUR STROKE CYCLE ENGINE (DIESEL/ PETROL ENGINE)

In four stroke cycle engines the four events namely suction, compression, power and exhaust take place inside the engine cylinder. The four events are completed in four strokes of the piston (two revolutions of the crank shaft). This engine has got valves for controlling the inlet of charge and outlet of exhaust gases. The opening and closing of the valve is controlled by cams, fitted on camshaft. The camshaft is driven by crankshaft with the help of suitable gears or chains. The camshaft runs at half the speed of the crankshaft. The events taking place in I.C. engine are as follows:

1. Suction stroke
2. Compression stroke
3. Power stroke
4. Exhaust stroke

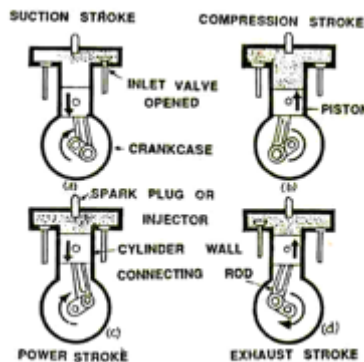

Four stroke cycle engine

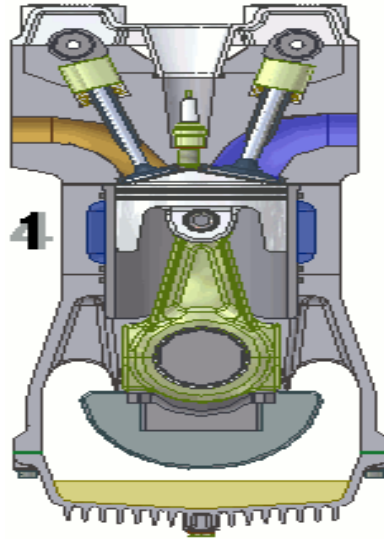

Four stroke cycle engine

Suction stroke

During suction stroke inlet valve opens and the piston moves downward. Only air or a mixture of air and fuel are drawn inside the cylinder. The exhaust valve remains in closed position during this stroke. The pressure in the engine cylinder is less than atmospheric pressure during this stroke (Fig. 1a)

Compression stroke

During this stroke the piston moves upward. Both valves are in closed position. The charge taken in the cylinder is compressed by the upward movement of piston. If only air is compressed, as in case of diesel engine, diesel is injected at the end of the compression stroke and ignition of fuel takes place due to high pressure and temperature of the compressed air. If a mixture of air and fuel is compressed in the cylinder, as in case of petrol engine, the mixture is ignited by a spark plug.

Power stroke

After ignition of fuel, tremendous amount of heat is generated, causing very high pressure in the cylinder which pushes the piston downward (Fig.1b). The downward movement of the piston at this instant is called power stroke. The connecting rod transmits the power from piston to the crank shaft and crank shaft rotates. Mechanical work can be taped at the rotating crank shaft. Both valves remain closed during power stroke.

Exhaust stroke

During this stroke piston moves upward. Exhaust valve opens and exhaust gases go out through exhaust valves opening. All the burnt gases go out of the engine and the cylinder

becomes ready to receive the fresh charge. During this stroke inlet valve remains closed (Fig.1d).

Thus it is found that out of four strokes, there is only one power stroke and three idle strokes in four stroke cycle engine. The power stroke supplies necessary momentum for useful work.

TWO STROKE CYCLE ENGINE (PETROL ENGINE)

In two stroke cycle engines, the whole sequence of events i.e., suction, compression, power and exhaust are completed in two strokes of the piston i.e. one revolution of the crankshaft. There is no valve in this type of engine. Gas movement takes place through holes called ports in the cylinder. The crankcase of the engine is air tight in which the crankshaft rotates.

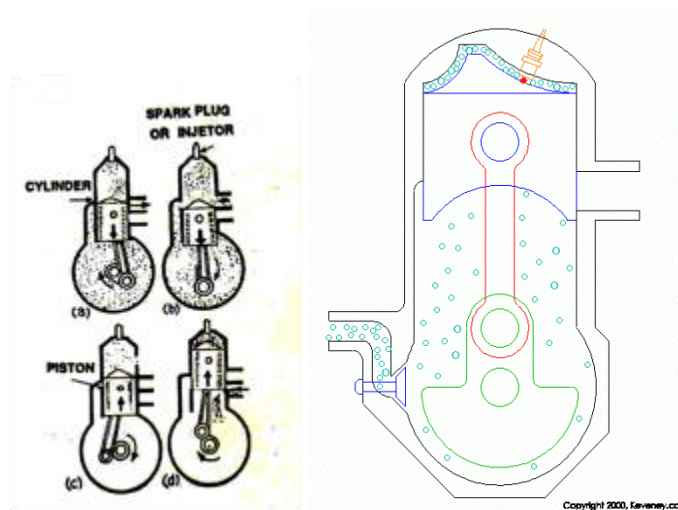

Two stroke cycle

Upward stroke of the piston (Suction + Compression)

When the piston moves upward it covers two of the ports, the exhaust port and transfer port, which are normally almost opposite to each other. This traps the charge of air- fuel mixture drawn already in to the cylinder. Further upward movement of the piston compresses the charge and also uncovers the suction port. Now fresh mixture is drawn through this port into the crankcase. Just before the end of this stroke, the mixture in the cylinder is ignited by a spark plug (Fig 2 c & d). Thus, during this stroke both suction and compression events are completed.

Downward stroke (Power + Exhaust)

Burning of the fuel rises the temperature and pressure of the gases which forces the piston to move down the cylinder. When the piston moves down, it closes the suction port, trapping the fresh charge drawn into the crankcase during the previous upward stroke. Further downward movement of the piston uncovers first the exhaust port and then the transfer port. Now fresh charge in the crankcase moves in to the cylinder through the transfer port driving out the

burnt gases through the exhaust port. Special shaped piston crown deflect the incoming mixture up around the cylinder so that it can help in driving out the exhaust gases . During the downward stroke of the piston power and exhaust events are completed.

COMPARISON BETWEEN TWO STROKE AND FOUR STROKE ENGINES

Four stroke engine	Two stroke engine
1. One power stroke for every two revolutions of the crankshaft.	One power stroke for each revolution of the crankshaft.
1. There are inlet and exhaust valves in the engine.	There are inlet and exhaust ports instead of valves.
1. Crankcase is not fully closed and air tight.	Crankcase is fully closed and air tight.
1. Top of the piston compresses the charge.	Both sides of the piston compress the charge.
1. Size of the flywheel is comparatively larger.	Size of the flywheel is comparatively smaller.
1. Fuel is fully consumed.	Fuel is not fully consumed.
1. Weight of engine per hp is high.	Weight of engine per hp is comparatively low.
1. Thermal efficiency is high.	Thermal efficiency is comparatively low.
1. Removal or exhaust gases easy.	Removal of exhaust gases comparatively difficult.
1. Torque produced is even.	Torque produced is less even.
1. For a given weight, engine would give only half the power of two stroke engine.	For same weight, two stroke engine gives twice the power that of four stroke engine.
1. All types of speed are possible (high and low).	Mostly high speed engines are there.
1. It can be operated in one direction only.	It can be operated in both direction (clockwise and counter clockwise).

WORKING PRINCIPLE OF DIESEL ENGINE

The basic components of diesel engine are cylinder, piston, injector, valves, connecting rod and crankshaft. In diesel engines only air is drawn into the cylinder. The engine has high compression ratio hence the air in the cylinder attains very high temperature and pressure at the end of the compression stroke. At the end of the compression stroke, the fuel is sprayed into the cylinder in atomized form using injectors. Due to high temperature, the fuel gets ignited, begins to burn and produce lot of heat. Due to the heat the gases expand, move the piston downward and rotate the crank shaft. The torque available at the rotating crank shaft is used to do any mechanical work

Special features of diesel engine

1. Engine has high compression ratio ranging from 14:1 to 22:1.
2. During compression stroke, the engine attains high pressure ranging from 30 to 45 kg/cm² and high temperature of about 500°C.
3. At the end of the compression stroke, fuel is injected into the cylinder through injectors (atomizers) at a very high pressure ranging from 120 to 200 kg/cm².
4. Ignition takes place due to heat of compression only.
5. There is no external spark in diesel engine.
6. Diesel engine has better slogging or lugging ability i.e. it maintains higher torque for a longer duration of time at a lower speed.

COMPARISON OF DIESEL ENGINE WITH PETROL ENGINE

Diesel engine	petrol engine
It has got no carburetor, ignition coil and spark plug.	It has got carburetor, ignition coil & spark plug.
Its compression ratio varies from 14:1 to 22:1	Its compression ratio varies from 5:1 to 8:1.
It uses diesel oil as fuel.	It uses petrol (gasoline) or power kerosine as fuel.
Only air is sucked in cylinder in suction stroke.	Mixture of fuel and air is sucked in the cylinder in suction stroke.
It has got 'fuel injection pump' and injector	It has got no fuel injection pump and injector, instead it has got carburetor and ignition coil.
Fuel is injected in combustion chamber where burning of fuel takes places due to heat of compression.	Air fuel mixture is compressed in the combustion chamber when it is ignited by an electric spark.
Thermal efficiency varies from 32 to 38%	Thermal efficiency varies from 25 to 32%
Engine weight per horse-power is high.	Engine weight per horsepower is comparatively low.
Operating cost is low.	Operating cost is high.
Compression pressure inside the cylinder varies	Compression pressure varies from 6 to 10

from 35 to 45 kg/cm² and temperature is about 500°C.

kg/cm² and temperature is above 260°C.

ENGINE COMPONENTS

Internal combustion engine consists of a number of parts which are given below :

1. **Cylinder:** It is a part of the engine which confines the expanding gases and forms the combustion space. It is the basic part of the engine. It provides space in which piston operates to suck the air or air-fuel mixture. The piston compresses the charge and the gas is allowed to expand in the cylinder, transmitting power for useful work. Cylinders are usually made of high grade cast iron.
2. **Cylinder block:** It is the solid casting body which includes the cylinder and water jackets (cooling fins in the air cooled engines).
3. **Cylinder head:** It is a detachable portion of an engine which covers the cylinder and includes the combustion chamber, spark plugs or injector and valves.
4. **Cylinder liner or sleeve:** It is a cylindrical lining either wet or dry type which is inserted in the cylinder block in which the piston slides. Liners are classified as : (1) Dry liner and (2) Wet liner.

Dry liner makes metal to metal contact with the cylinder block casing. wet liners come in contact with the cooling water, whereas dry liners do not come in contact with the cooling water.

5. **Piston:** It is a cylindrical part closed at one end which maintains a close sliding fit in the engine cylinder. It is connected to the connecting rod by a piston pin. The force of the expanding gases against the closed end of the piston, forces the piston down in the cylinder. This causes the connecting rod to rotate the crankshaft (Fig 3). Cast iron is chosen due to its high compressive strength. Aluminum and its alloys preferred mainly due to it lightness.

1. Due to it lightness.

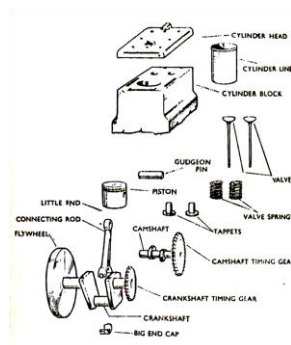

Engine components

Head (Crown) of piston: It is the top of the piston.

Skirt: It is that portion of the piston below the piston pin which is designed to adsorb the side movements of the piston.

1. **Piston ring:** It is a split expansion ring, placed in the groove of the piston. They are usually made of cast iron or pressed steel alloy (Fig.3). The function of the ring are as follows :
2. It forms a gas tight combustion chamber for all positions of piston.
3. It reduces contact area between cylinder wall and piston wall preventing friction losses and excessive wear.
4. It controls the cylinder lubrication.
5. It transmits the heat away from the piston to the cylinder walls.

Piston rings are of two types: (1) Compression ring and (2) Oil ring

vii) Compression ring

Compression rings are usually plain, single piece and are always placed in the grooves of the piston nearest to the piston head. They prevent leakage of gases from the cylinder and helps increasing compression pressure inside the cylinder.

Oil ring: Oil rings are grooved or slotted and are located either in lowest groove above the piston pin or in a groove above the piston skirt. They control the distribution of lubrication oil in the cylinder and the piston.

Piston Pin: It is also called wrist pin or gudgeon pin. Piston pin is used to join the connecting rod to the piston.

viii) Connecting rod: It is special type of rod, one end of which is attached to the piston and the other end to the crankshaft (Fig.3). It transmits the power of combustion to the crankshaft and makes it rotate continuously. It is usually made of drop forged steel.

ix) Crankshaft: It is the main shaft of an engine which converts the reciprocating motion of the piston into rotary motion of the flywheel (Fig.3). Usually the crankshaft is made of drop forged steel or cast steel. The space that supports the crankshaft in the cylinder block is called *main journal*, whereas the part to which connecting rod is attached is known as *crank journal*.

Crankshaft is provided with counter weights throughout its length to have counter balance of the unit.

x) Flywheel: Flywheel is made of cast iron. Its main functions are as follows :

1. It stores energy during power stroke and returns back the energy during the idle strokes, providing a uniform rotary motion of flywheel.
2. The rear surface of the flywheel serves as one of the pressure surfaces for the clutch plate.
3. Engine timing marks are usually stamped on the flywheel, which helps in adjusting the timing of the engine.
4. Sometime the flywheel serves the purpose of a pulley for transmitting power.

Crankcase: The crankcase is that part of the engine which supports and encloses the crankshaft and camshaft. It provides a reservoir for the lubricating oil. It also serves as a mounting unit for such accessories as the oil pump, oil filter,, starting motor and ignition components. The upper portion of the crankcase is usually integral with cylinder block. The lower part of the crankcase is commonly called oil pan and is usually made of cast iron or cast aluminum.

Camshaft: It is a shaft which raises and lowers the inlet and exhaust valves at proper times. Camshaft is driven by crankshaft by means of gears, chains or sprockets (Fig3). The speed of the camshaft is exactly half the speed of the crankshaft in four stroke engine. Camshaft operates the ignition timing mechanism, lubricating oil pump and fuel pump. It is mounted in the crankcase, parallel to the crankshaft.

Timing gear: Timing gear is a combination of gears, one gear of which is mounted at one end of the camshaft and the other gear at the crankshaft. Camshaft gear (fig.) is bigger in size than that of the crankshaft gear and it has twice as many teeth as that of the crankshaft gear. For this reason, this gear is commonly called half time gear. Timing gear controls the timing of ignition, timing of opening and closing of valve as well as fuel injection timing.

Inlet manifold: It is that part of the engine through which air or air-fuel mixture enters into the engine cylinder. It is fitted by the side of the cylinder head.

Exhaust manifold: It is that part of the engine through which exhaust gases go out of the engine cylinder. It is capable of withstanding high temperature of burnt gases. It is fitted by the side of the cylinder head.

xiv) Top dead centre - When the piston is at the top of its stroke, it is said to be at the *top dead centre* (TDC),

xv) Bottom dead centre - when the piston is at the bottom of its stroke, it is said to be at its bottom dead centre (BDC).

In two stroke cycle engine both the sides of the piston are effective which is not the case in four stroke cycle engine.

xvi) Scavenging

The process of removal of burnt or exhaust gases from the engine cylinder is known as scavenging. Entire burnt gases do not go out in normal stroke, hence some type of blower or compressor is used to remove the exhaust gases in two stroke cycle engine.

TERMINOLOGY CONNECTED WITH ENGINE POWER

Bore- Bore is the diameter of the engine cylinder.

Stroke - It is the linear distance traveled by the piston from Top dead centre (TDC) to Bottom dead centre (BDC).

Stroke-bore ratio -The ratio of length of stroke (L) and diameter of bore (D) of the cylinder is called stroke-bore ratio (L/D). In general, this ratio varies between 1 to 1.45 and for tractor engines, this ratio is about 1.25.

Swept volume - It is the volume (A x L) displaced by one stroke of the piston where A is the cross sectional area of piston and L is the length of stroke (Fig.4).

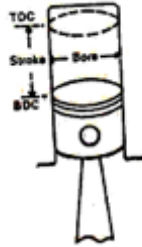

Bore and stroke of IC engine

Compression ratio - It is the ratio of the volume of the cylinder at the beginning of the compression stroke to that at the end of compression stroke, i.e. ratio of total cylinder volume to clearance volume.

The Compression ratio of diesel engine varies from 14:1 to 22:1 and that of carburetor type engine (spark ignition engine) varies from 4:1 to 8:1.

Power - It is the rate of doing work. S.I. unit of power is watt.

Watt = Joule/sec. (4.2 Joules = 1 Calorie).

In metric unit the power can be expressed in kg.m/sec.

Horse power (HP) - It is the rate of doing work. Expressed in horse power

Conversion factors from work to power

4500 kg m of work /minute = 1.0 hp

75 kg. m of work /second = 1.0 hp.

Indicated horse power (IHP) - It is the power generated in the engine cylinder and received by the piston. It is the power developed in a cylinder without accounting frictional losses.

$$\text{IHP} = \frac{PLAN}{4500} \times \frac{n}{2} \quad (\text{for four stroke engine})$$

$$\text{IHP} = \frac{PLAN}{4500} \times n \quad (\text{for two stroke engine})$$

Where P = mean effective pressure, kg/cm²

L = stroke length, m

A = cross sectional area of piston, cm²

N = engine revolution per minute

n = number of cylinders

In SI unit, indicated horse power is given as below:

$$\text{Indicated horse power (IHP), kW} = \frac{PLAN}{60 \times 1012} \times n \quad (\text{for four strike engine})$$

$$\text{Indicated power (ip), kW} = \frac{PLAN}{60 \times 1012} \times n \quad (\text{for two strike engine})$$

where P = mean effective pressure, Pa (pascal)

L = length of stroke, mm

A = area of piston, mm²

N = speed, RPM

Brake horse power (BHP) - It is the power delivered by the engine at the end of the crankshaft. It is measured by a dynamometer.

$$\text{BHP} = \frac{2\pi NT}{4500} \text{ hp}$$

where T = Torque in kg.m

N = speed, RPM

Belt horse power - It is the power of the engine measured at a pulley receiving drive from the PTO shaft of the tractor.

Power take-off horse power (PTO HP) - It is the power delivered by a tractor through its PTO shaft. In general, the belt and PTO horse power of a tractor will approximately be the same. The PTO hp is around 80-85% of tractor engine power

Drawbar horse power (DBHP) - It is the power of a tractor measured at the drawbar of a tractor. It is that power which is available for pulling loads. It is around 50-55 % of engine power.

Frictional horse power (FHP) - It is the power required to run the engine at a given speed without producing any useful work. It represents the friction and pumping losses of an engine.

$$\text{IHP} = \text{BHP} + \text{FHP}$$

MODEL QUESTIONS

1. List the advantages of diesel engine
2. Mention the basic components of an IC Engine
3. List the types of engine classification
4. Mention the four strokes of IC engine with a neat sketch and explain their role
5. Differentiate petrol and diesel engine
6. Mention merits and demerits of different farm power sources.
7. Differentiate IHP and BHP
8. Write about the working of four stroke cycle engine
9. Write about the working of two stroke cycle engine
10. Compare four stroke cycle engine with two stroke cycle engine
11. Compare spark ignition engine with compression engine



Lecture 03

DIFFERENT SYSTEMS OF IC ENGINE - COOLING, LUBRICATING, FUEL INJECTION SYSTEMS

Different systems available for efficient functioning of an engine are as follows

1. fuel supply system
2. lubrication system
3. ignition system
4. cooling system
5. governor

Fuel is a substance consumed by the engine to produce power. The common fuel for Internal Combustion engines are

1. Petrol
2. Power kerosene
3. High speed diesel

Calorific value of fuel

The heat liberated by combustion of a fuel is known as calorific value or heat value of the fuel. It is expressed in kcal/kg of the fuel

Sl. No	Name of fuel	Calorific value, kcal/kg
1	Light Diesel Oil (L.D.O)	10300
2	High speed diesel oil (HSD)	10550
3	Power kerosene	10850
4	Petrol	11100

FUEL SUPPLY SYSTEM IN SPARK IGNITION ENGINE

The fuel supply system of spark ignition engine consists of

1. Fuel tank
2. Sediment bowl
3. Fuel lift pump
4. Carburetor
5. Fuel pipes

In some spark ignition engines the fuel tank is placed above the level of the carburetor. The fuel flows from fuel tank to the carburetor under the action of gravity. There are one or two

filters between fuel tank and carburetor. A transparent sediment bowl is also provided to hold the dust and dirt of the fuel. If the tank is below the level of carburetor, a lift pump is provided in between the tank and the carburetor for forcing fuel from tank to the carburetor of the engine. The fuel comes from fuel tank to sediment bowl and then to the lift pump. From there the fuel goes to the carburetor through suitable pipes. From carburetor the fuel goes to the engine cylinder through inlet manifold of the engine.

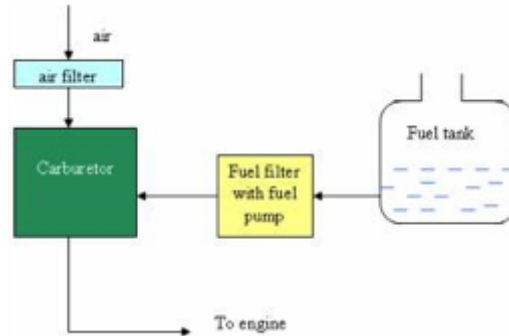

Carburetor

The process of preparing air-fuel mixture away from the engine cylinder is called carburation, and the device in which this process takes is called carburetor.

Functions of carburetor

1. To mix the air and fuel thoroughly
2. To atomize the fuel
3. To regulate the air- fuel ratio at different speeds and loads on the engine.
4. to supply correct amount of mixture at different speeds and loads

FUEL SUPPLY SYSTEM IN DIESEL ENGINE

Fuel supply system of diesel engine consists of the following components

1. Fuel tank
2. Fuel lift pump or fuel feed pump
3. Fuel filter
4. Fuel injection pump
5. High pressure pipe
6. Over flow valve
7. Fuel injector

Fuel is drawn from fuel tank by fuel feed pump and forced to injection pump through fuel filter. The injection pump supplies high pressure fuel to injection nozzles through delivery valves and high pressure pipes. Fuel is injected into the combustion chamber through injection nozzles. The fuel that leaks out from the injection nozzles passes out through leakage pipe and returns to the fuel tank through the over flow pipe.

Over flow valve installed at the top of the filter keeps the feed pressure under specified limit. If

the feed pressure exceeds the specified limit, the over flow valve opens and then the excess fuel returns to fuel tank through over flow pipe.

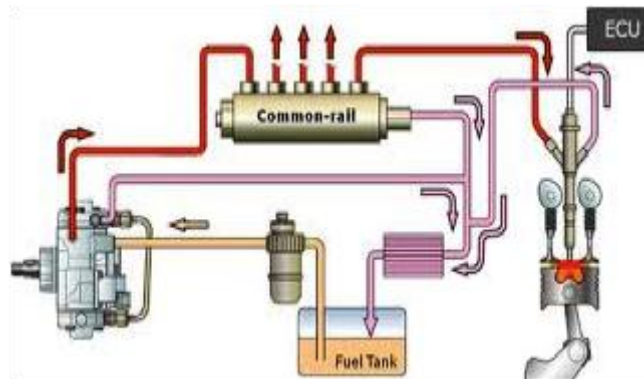

Fuel tank

It is a storage tank for diesel. A wire gauge strainer is provided under the cap to prevent foreign particles entering the tank.

Fuel lift pump

It transfers fuel from fuel tank to inlet gallery of fuel injection pump

Preliminary filter (sediment bowl assembly)

This filter is mostly fitted on fuel lift pump. It prevents foreign materials from reaching inside the fuel line. It consists of a glass cap with a gasket.

Fuel filter

Mostly two stage filters are used in diesel engines

1. Primary filter
2. Secondary filter

Primary filter removes coarse materials, water and dust. Secondary filter removes fine dust particles.

Fuel injection pump

It is a high pressure pump which supplies fuel to the injectors according to the firing order of the engine. It is used to create pressure varying from 120 kg/cm² to 300 kg/cm². It supplies the required quantity of fuel to each cylinder at appropriate time.

Air venting of fuel system

When air has entered the fuel lines or suction chamber of the injection pump, venting should be done properly.. Air is removed by the priming pump through the bleeding holes of the injection pump.

Fuel injector

It is the component which delivers finely atomized fuel under high pressure to combustion chamber of the engine. Modern tractor engines use fuel injectors which have multiple holes.

Main parts of injectors are nozzle body, and needle valve. The needle valve is pressed against a conical seat in the nozzle body by a spring. The injection pressure is adjusted by adjusting a screw. In operation, fuel from injection pump enters the nozzle body through high pressure pipe. When fuel pressure becomes so high that it exceeds the set spring pressure, the needle valve lifts off its seat. The fuel is forced out of the nozzle spray holes into the combustion chamber.

LUBRICATION SYSTEM

IC engine is made of moving parts. Duo to continuous movement of two metallic surfaces over each other, there is wearing of moving parts, generation of heat and loss of power in engine. Lubrication of moving parts is essential to prevent all these harmful effects.

Purpose of lubrication-

1. **Reducing frictional effect**
2. **Cooling effect**
3. **Sealing effect**
4. **Cleaning effect**

Types of lubricants

Lubricants are obtained from animal fat, vegetables and minerals. Vegetable lubricants are obtained from seeds, fruits and plants. Cotton seed oil, olive oil, linseed oil, castor oil are used as lubricants. Mineral lubricants are most popular for engines and machines. It is obtained from crude petroleum found in nature.. Petroleum lubricants are less expensive and suitable for internal combustion engines

Engine lubrication system

The lubricating system of an engine is an arrangement of mechanisms which maintains the supply of lubricating oil to the rubbing surfaces of an engine at correct pressure and temperature.

The parts which require lubrication are

1. Cylinder walls and piston]
2. Piston pin
3. crankshaft and connecting rod bearings
4. Camshaft bearings
5. Valve operating mechanism
6. Cooling fan
7. Water pump and
8. Ignition mechanism

Types of lubricating systems

1. Splash system
2. Forced feed system

IGNITION SYSTEM

Fuel mixture of IC engine must be ignited in the engine cylinder at proper time for useful work. Arrangement of different components for providing ignition at proper time in the engine cylinder is called Ignition system

Types of ignition systems

1. Ignition by electric spark or spark ignition
2. Ignition by heat of compression or compression ignition
3. Ignition by hot tube or hot bulb
4. Ignition by open fire

Only the first two are important methods for modern engines

SPARK IGNITION

the purpose of spark ignition is to deliver a perfectly timed surge of electricity across an open gap in each cylinder at the exact moment so that the charge may start burning with maximum efficiency

Two types of spark ignition are a) Battery ignition b) magneto ignition

MAGNETO IGNITION SYSTEM

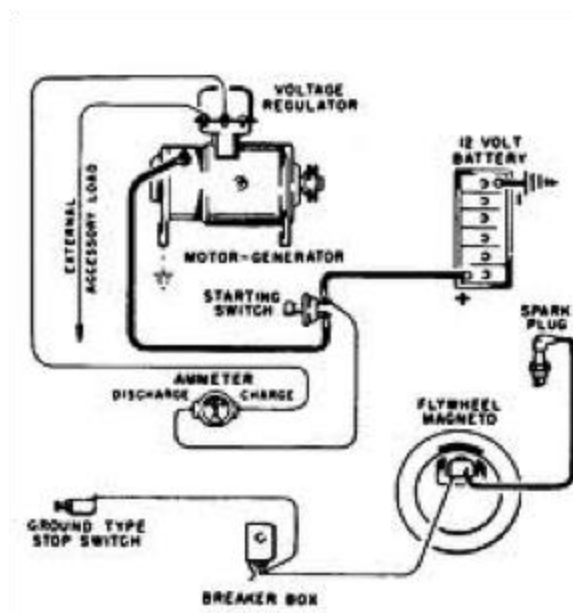

In magneto ignition system a magneto is used to generate electric current for producing spark. A high tension magneto generates a very high voltage needed for spark plug

Main components of magneto ignition system

- a) Frame
- b) Permanent magnet
- c) Armature
- d) Soft iron field
- e) rotor
- f) Primary and secondary winding
- g) Breaker points
- h) Condenser

The armature consists of an iron core on which there are two sets of windings

- 1) Primary
- 2) Secondary

The armature is driven by the engine. As the armature rotates, primary windings cut the lines of force of magnetic field and induced current flows in the primary circuit. As the primary current reaches its maximum value in each direction, the primary circuit is suddenly opened by a contact breaker and the current collapses. This action induces a very high voltage in the secondary winding which causes a momentary spark to jump at the spark plug gap. A distributor is provided which carries current to the spark plug through high tension wires. The condenser is used to eliminate the arcing at the breaker points and intensifying the current in the secondary circuit. For multi cylinder engines, a distributor and a rotor are required to distribute the current to different spark plugs.

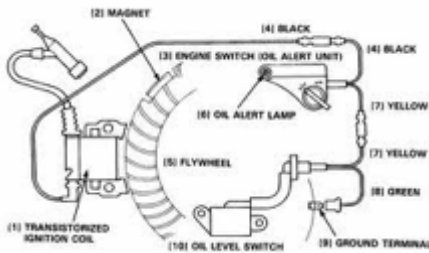

Magneto ignition system

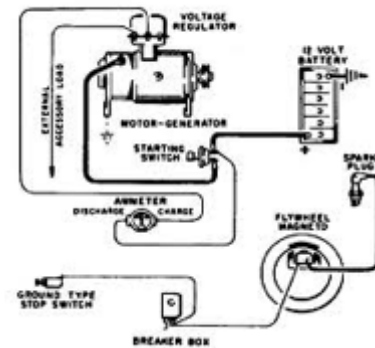

Magneto ignition system

COOLING SYSTEM

Fuel is burnt inside the cylinder of an internal combustion engine to produce power. The temperature produced on the power stroke of an engine can be as high as 1600 °C and this is greater than melting point of engine parts.. The best operating temperature of IC engines lie between 140 F and 200 °F and hence cooling of an IC engine is highly essential. . It is estimated

that about 40% of total heat produced is passed to atmosphere via exhaust, 30% is removed by cooling and about 30% is used to produce power.

Purpose of cooling

1. To maintain optimum temperature of engine for efficient operation under all conditions.
2. To dissipate surplus heat for protection of engine components like cylinder, cylinder head, piston, piston rings, and valves
3. To maintain the the lubricating property of oil inside engine

Methods of cooling

1. Air cooled system
2. Water cooled system

AIR COOLING SYSTEM

Air cooled engines are those engines in which heat is conducted from the working components of the engine to the atmosphere directly.

Principle of air cooling- The cylinder of an air cooled engine has fins to increase the area of contact of air for speedy cooling. The cylinder is normally enclosed in a sheet metal casing called cowling. The fly wheel has blades projecting from its face, so that it acts like a fan drawing air through a hole in the cowling and directed it around the finned cylinder. For maintenance of air cooled system, passage of air is kept clean by removing grasses etc. by a stiff brush of compressed air.

Advantages of air cooled engine

1. It is simple in design and construction
2. Water jackets, radiators, water pump, thermostat, pipes, hoses are not required
3. It is more compact
4. Lighter in weight

Disadvantages

1. There is uneven cooling of engine parts
2. Engine temperature is generally high during working period



Air cooled engine

WATER COOLING SYSTEM

Engines using water as cooling medium are called water cooled engines. Water is circulated round the cylinders to absorb heat from the cylinder walls. The heated water is conducted through a radiator to remove the heat and cool the water.

Methods of water cooling

1. Open jacket or hopper method
2. Thermo siphon method
3. Forced circulation method

1. Open jacket method

There is a hopper or jacket containing water which surrounds the engine cylinder. So long as the hopper contains water the engine continues to operate satisfactorily. As soon as the water starts boiling it is replaced by cold water.. The hopper is large enough to run for several hours without refilling. A drain plug is provided in a low accessible position for draining water as and when required.

2. Thermo siphon method

It consists of a radiator, water jacket, fan, temperature gauge and hose connections. The system is based on the principle that heated water which surrounds the cylinder becomes lighter and it rises upwards in liquid column. Hot water goes to the radiator where it passes through tubes surrounded by air. Circulation of water takes place due to the reason that water jacket and radiator are connected at both sides i.e. at top and bottom. A fan is driven with the help of a V belt to suck air through tubes of the radiator unit, cooling radiator water. The disadvantage of the system is that circulation of water is greatly reduced by accumulation of scale or foreign matter in the passage and consequently causing over heating of the engine.

3. Forced Circulation system

In this method, a water pump is used to force water from radiator to the water jacket of the engine. After circulating the entire run of water jacket, water comes back to the radiator where

it loses its heat by the process of radiation. To maintain the correct engine temperature , a thermostat valve is placed at the outer end of cylinder head. Cooling liquid is by-passed through the water jacket of th3e engine until the engine attains the desired temperature. The thermostat valve opens and the by-pass is closed, allowing the water to go to the radiator. The system consists of the following components

1. Water pump
2. Radiator
3. Fan
4. Fan-belt
5. Water jacket
6. Thermostat valve
7. Temperature gauge
8. Hose pipe

Water pump

It is a centrifugal pump. It draws the cooled water from bottom of the radiator and delivers it to the water jackets surrounding the engine.

Thermostat valve

It is a control valve used in cooling system to control the flow of water when activated by a temperature signal.

Fan

The fan is mounted on the water pump shaft. It is driven by the same belt that drives the pump and dynamo. The purpose of radiator is to provide strong draft of air through the radiator to improve engine cooling

Water jacket - Water jackets are passages cored out around the engine cylinder as well as around the valve opening

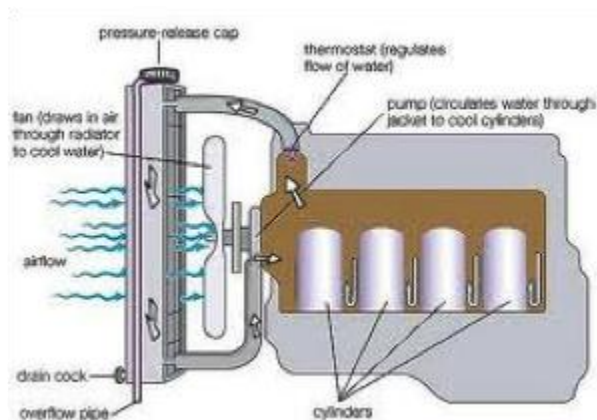

Forced Circulation cooling system- Water cooled engine

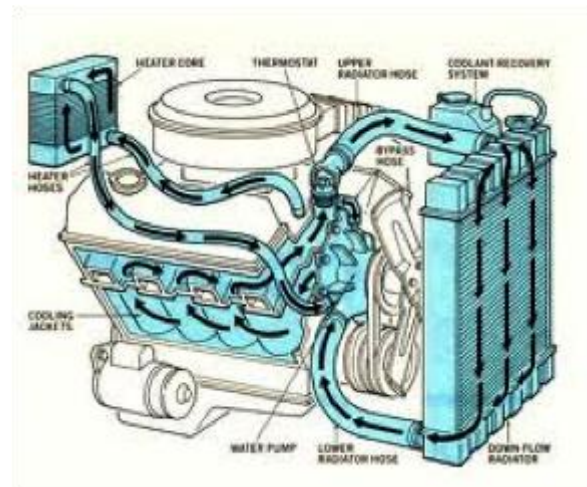

Forced Circulation cooling system- Water cooled engine

GOVERNOR

Governor is mechanical device, designed to control the soeed of the engine with in specified limit., used on tractor or stationary engine for

1. Maintaining a nearly constant speed of engine under different load conditions
2. Protecting the engine and attached equipments against high speeds, when the load is removed or reduced

Types of governors

1. Centrifugal governor
2. Pneumatic governor
3. Hydraulic governor

Governor regulation

The governor is fitted on an engine for maintaining a constant speed, even then some variation in speed is observed at full load and no load conditions. In normal working, a variation of about 100 rev/min is observed between full load and no load conditions for a good governor. Hence it is possible to regulate the governor to maintain a higher or lower speed by changing the tension of the spring. The extent of regulation done, is expressed in terms of percentage called percentage regulation. This is also called speed drop. It is the variation in the engine speed between full load and no load condition. It is usually expressed as percentage of rated speed. This is given by

$$R = \frac{N_1 - N_2}{(N_1 + N_2)/2} \times 100$$

Where,

R - % regulation,

N₁ - Speed at no load, rpm

N₂ - Speed at full load, rpm

Problem- Find the percentage regulation in a governor if speed at no load is 1600 rev/min and at full load is 1500 rev/min

Governor hunting

Governor hunting is the erratic variation of the speed of the governor when it overcompensates for speed changes. When the governor produces a periodic effect on the engine speed like too fast and then too slow, then too fast and so on it is a sign of governor hunting. In such cases it is observed that when the engine speeds up quickly, the governor suddenly responds, the speed drops quickly, the governor again responds and this process is repeated. The reason for governor hunting may be due to incorrect adjustment of fuel pump or carburetor, improper adjustment of the idling screw and excessive friction. Hunting may be due to governor being too stiff or due to some obstruction in free movement of governor components.

Lecture 04 TRACTORS- TYPES AND UTILITIES

Tractor is a self propelled power unit having wheels or tracks for operating agricultural implements and machines including trailers. Tractor engine is used as a prime mover for active tools and stationary farm machinery through power-take off (pto) or belt pulley



wheel tractors

TRACTOR DEVELOPMENT

The present tractor is the result of gradual development of machine in different stages. History of tractor development is given below.

1890- The word tractor appeared first on record in a patent issued on a tractor or traction engine invented by George H. Harris of Chicago

1906- Successful gasoline tractor was introduced by Charles w. Hart and Charles H. Parr of Charles City, Iowa

1908- First Winnipeg tractor trails were held

1911- First tractor demonstration was held at Omaha (Nebraska)

1915-1919- Power take off was introduced

1920-1924- All purpose was developed

1936- 1937 - Diesel engine was used in tractor and pneumatic tires were introduced

1950-1960- Manufacturing of diesel tractors on extensive basis throughout the world was taken up

1960-1961 - Tractor manufacturing was started in India by first manufacturer M/s Eicher Good Earth

1962-1970 – Manufacturers like Tractor and Farm Equipment , Madras , Hindustan tractors at Baroda, Escorts Tractors at Faridabad and International Harvester in Bombay started work during this period

1971- Escorts Tractor Ltd. Started producing Ford Tractors

1973- Manufacture of HMT Tractor was started

1974- Manufacture of Pitti and Kirlosker Tractor was started

1975- Harsha Tractors was established

1981- Auto tractors were started

1982- Universal Tractors was established

1983-2003- GTCL tractors, M.M Tractors, Sonalika, VST, L&T, Bajaj Tractors were produced

CLASSIFICATION OF TRACTORS

Tractors can be classified into three classes on the basis of structural design

1. Wheel tractor
2. crawler tractor
3. walking type tractor

Wheel tractor

Tractors having three or four pneumatic wheels are called wheel tractors. Four wheel tractors are popular everywhere



Three wheel tractor



Four wheel tractor

Crawler tractor

This type is also called Track type tractor or Chain type tractor. In such tractors , there is endless chain or track in place of pneumatic wheels



Crawler tractors

Power tiller

Power tiller is a walking type tractor. This tractor is usually fitted with two wheels only. The direction of travel and its controls for field operation is performed by the operator, walking behind the tractor



Power tillers

Classification of wheel tractors

On the basis of purpose, wheeled tractors are classified into three groups

- a. General purpose tractor
- b. Row crop tractor
- c. Special purpose tractor

a) General purpose tractor

It is used for major farm operations such as ploughing, sowing, harvesting and transporting works. Such tractors have i) low ground clearance ii) Increased engine power iii) good adhesion and iv) wide tyres



General purpose tractors

b) Row crop tractors

It is used for row crop cultivation. Such tractor is provided with replaceable driving wheels of different tread widths. It has high ground clearance to save damage of crops. Wide wheel track can be adjusted to suit inter row distance



Row crop tractors

c) Special purpose tractor

It is used for definite jobs like cotton fields, marshy lands, hill sides, garden etc. special designs are there for special purpose tractor.

Eg. a) Tractor with winch unit b) multi drive tractor c) tractor for golf grounds etc.



Tractor with winch unit



Multi drive tractors



Tractor for golf grounds

SELECTION OF TRACTOR

Selection of tractors depend up on following factors

1. **Land holding:** Under a single cropping pattern, it is normally recommended to consider 1 hp for every 2 hectare of land. In other words , one tractor 20-25 hp is suitable for 40 hectare farm
2. **Cropping pattern:** Generally 1.5 hectare/hp has been recommended where adequate irrigation facility are available and more than one crop is taken. So a 30-35 hp tractor is suitable for 40 hectare of land.
3. **Soil condition:** A tractor with less wheel base , higher ground clearance and low overall weight may work successfully in lighter soils buy will not be able to give sufficient depth in black cotton soils

4. **Climatic condition:** For very hot zone and desert area, air cooled engines are preferred over water cooled engines. Similarly for higher altitude air cooled engines are preferred because water cooled engines are liable to be frozen at high altitudes
5. **Repair facilities:** It should be ensured that the tractor to be purchased has a dealer at near by place with all the technical skills for repair and maintenance of the machine.
6. **Running cost:** Tractors with less specific fuel consumption should be preferred over others so that the running cost may be less.
7. **Initial cost and resale value:** While keeping the resale value in mind , the initial cost should not be very high, otherwise higher amount of interest have to be paid

Test report: Test report of tractors released from farm machinery testing stations should be consulted for guidance

WHEEL TRACTOR

Components

1. I.C Engine
2. Clutch
3. Transmission gears
4. Differential unit
5. Final drive
6. Real wheel
7. Front wheels
8. Steering mechanism
9. Hydraulic control and hitch system
10. Brakes
11. Power-take-off unit
12. Tractor pulley
13. Draw bar and
14. Control panel
15. **I.C engine**

Internal combustion of suitable horse power is used as a prime mover in a tractor. Engines ranging from 8 to 200 hp are used in agricultural tractors. In India , four wheel tractors for agricultural operations are fitted with 25-80 hp. Walking type tractors are fitted with 8-12 hp engines

1. Clutch

Clutch is a device, used to connect and disconnect the tractor engine from the transmission gears and drive wheels. Clutch transmits power by means of friction between driving members and driven members

Necessity of clutch in a tractor

1. Engine needs cranking by any suitable device. For easy cranking, the engine is disconnected from the rest of the transmission unit by the clutch. After starting the engine, the clutch is engaged to transmit the power from engine to gear box
2. In order to change the gears, the gear box must be kept free from engine power, otherwise the gear teeth will be damaged and engagement of gears will be difficult. This work is done by clutch
3. When the belt pulley of the tractor works in the field it needs to be stopped without stopping the engine. This is done by a clutch

3. Power transmission system of a tractor)

Transmission is a speed reducing mechanism, equipped with several gears. It may be called a sequence of gears and shafts, through which the engine power is transmitted to the tractor wheels. The system consists of various devices, which cause forward and backward movement of tractor to suit different field conditions. The complete path of power from engine to wheel is called power train

Functions of power transmission system

1. To transmit power from the engine to the rear wheels of the tractor
2. To make reduced speed available, to rear wheels of the tractor
3. To alter the ratio of wheel speed and engine speed in order to suit the field conditions
4. To transmit power through right angle drive, because the crankshaft and rear axle are normally at right angles to each other.

The power transmission system consists of :

1. Clutch
2. Transmission gears
3. Differential
4. Final drive
5. Rear axle
6. Rear wheels

4. Transmission gears

A tractor runs at high speed, but the rear wheel of the tractor requires power at low speed and high torque. That's why it becomes essential to reduce the engine speed and increase the torque available at the rear wheel of the tractor because

$$\text{Power, kW} = \frac{2\pi NT}{60 \times 1000}$$

Where,

T is torque in Newton -meter

N = speed in rev/ min

If engine power is constant, it is obvious that for higher torque at wheels , low speed is required and vice versa.. So gear box is fitted between engine and rear wheels for variable speed and torque.

1. Differential unit

Differential unit is a special arrangement of gears to permit one of the rear wheels of the tractor to rotate slower or faster than the other. While turning the tractor on a curved path, the inner wheel has to travel lesser distance than the outer wheel. The inner wheel requires lesser power than the outer wheel. This condition is fulfilled by differential unit, which permits one of the rear wheels of the tractor to move faster than the other at a turning point.

Differential Lock

Differential lock is a device to join both half axles of the tractor so that even if one wheel is less resistance, the tractor comes out of the mud etc. as both wheels move with the same speed and apply equal traction.

1. Final drive

Final drive is a gear reduction unit in the power trains between differentials and drive wheels. Final drive transmits the power finally to the rear axle and the wheels. The tractor rear wheels are not directly attached to the half shafts but the drive is taken through a pair of spur gears. Each half shaft terminates in a small gear which meshes with a large gear called bull gear. The bull gear is mounted on a shaft, carrying the tractor rear wheel. The device for final speed reduction, suitable for tractor rear wheels is known as final drive mechanism.

1. Steering mechanism

The system, governing the angular movement of front wheels of a tractor is called steering system. This system minimizes the efforts of the operator in turning the front wheels with the application of leverages. The different components of steering system are i) steering wheel ii) steering shaft iii) steering gear iv) drag link v) steering arm vi) tie rod vii) king pin. When the operator turns the steering wheel, the motion is transmitted through the steering shaft to the angular motion of the pitman arm through a set of gears. The angular movement of the pitman arm is further transmitted to the steering arm through drag link and tie rods. Steering arm are keyed to the respective king pins which are integral part of the stub axle on which wheels are mounted. The movement of steering arm affects the movement of front wheel.

1. Hydraulic control system

It is a mechanism in a tractor to raise, hold or lower the mounted implement or semi-mounted equipments by hydraulic means. All tractors are equipped with hydraulic control system for operating three point hitch of the tractor. Hydraulic system works on PASCAL'S Law which states that pressure applied to an enclosed fluid is transmitted equally in all directions.

Basic components of hydraulic system

1. Hydraulic pump
2. Hydraulic cylinder and piston
3. Hydraulic tank
4. Control valve
5. Safety valve
6. Hose pipe and fittings
7. Lifting arms

The hydraulic pump draws up oil from the oil reservoir and sends it to the control valve under high pressure. From the control valve, the oil goes to the hydraulic cylinder to operate the piston, which in turn, raises the arms. The implements attached with the arms are lifted up.

1. Brakes

Brake is used to stop or slow down the motion of the tractor. It is mounted on the driving axle and operated by two independent pedals. Each pedal can be operated independently to assist the turning of tractor during field work or locked together by means of a lock.

Types of brakes - a) Mechanical brake b) hydraulic brake

1. Power take off

It is a part of tractor transmission system. It consists of a shaft, a shield and a cover. The shaft is externally splined to transmit torsional power to another machine. A rigid guard fitted on a tractor covers the power-take-off shaft as a safety device. The guard is called power take off shield. As per ASAE standards PTO speed is 540 ± 10 rpm when operating under load. In order to operate 1000 rpm PTO drive machine, a new standard has been developed.



PTO on a tractor



PTO drive

1. Belt pulley

All tractors are provided with a belt pulley. The function of the pulley is to transmit power from the tractor to stationary machinery by means of a belt. It is used to operate thresher, centrifugal pump, silage cutter, and several other machinery. The pulley is located either on

the left, right or rear side of the tractor. Pulley drive is engaged or disengaged from the engine by means of a clutch.



Belt pulley connected to tractor PTO

1. Control board or dash board

The control board of a tractor generally consists of

1. Main switch
2. Throttle
3. Decompression lever
4. Hour meter
5. Light switch`
6. Horn button
7. Battery charging indicator
8. oil pressure indicator
9. Water temperature gauge

1. Main switch - When the main switch is on , the electric current floes in the electric circuit
2. Throttle lever - This lever is for increasing or decreasing the speed of the engine.
3. Decompression lever - This lever releases the compression pressure from the combustion chamber of the engine and helps to start the engine.
4. Hour meter - This meter indicates the engine hour as well as engine revolution per minute
5. Light switch - light switch is for light points only
6. Horn button - This is for horn of the tractor
7. Battery charger indicator - This indicates the charge and discharge of the battery.
8. Oil pressure indicator - this indicates the lubricating oil pressure in the system
9. Water temperature gauge - this indicates the temperature of water of the cooling system



Tractor dash board

IMPORTANT TERMS CONNECTED WITH TRACTORS

1. **Wheel base:** Wheel base is the horizontal distance between the front and rear wheels of a tractor
2. **Ground clearance:** It is the height of the lowest point of the tractor from the ground surface, the tractor being loaded to its permissible weight
3. **Track:** Track is the distance between the two wheels of the tractor on the same axle., measured at the ground contact
4. **Turning space:** It is the diameter of the smallest circle , described by the outer most point of the tractor, while moving at a speed not exceeding 3 km/hr with the steering wheels in full lock.
5. **Cage wheels:** It is a wheel or an attachment to a wheel with spaced cross bars for improving traction of the tractor in a wet field. It is generally used in paddy field

CRAWLER TRACTOR

A crawler tractor (also called: track-type tractor, tractor crawler, or track-laying vehicle) is a vehicle that runs on continuous tracks instead of wheels. In agriculture they are used for land clearing and land leveling works. The principal advantages of crawler tractor over wheeled tractors are that they are in contact with a larger surface area than the wheeled tractor, and as a result exert a much lower force per unit area on the ground than a conventional wheeled tractor of the same weight. This makes them suitable for use on soft, low friction and uneven ground such as mud, ice and snow. The principal disadvantage is that tracks are a more complex mechanism than a wheel, and relatively prone to failure modes such as snapped or derailed tracks.



Crawler tractor or chain type tractor has the following characterizes

1. It is designed to secure good adhesion and transmit high drawbar pull in difficult field conditions, where wheel tractors fail to secure adequate grip on the soil
2. It provides large area of contact with the ground
3. It is useful at places where adhesion is difficult and rolling resistance is high
4. It is most suited for heavy work, specially earth moving work and reclamation work
5. It is used for all types of agricultural works with heavy implements

Crawler type tractors mainly consists of

1. Track frame assembly
2. Track chain
3. Steering clutch
4. steering brake

POWER TILLER

It is a prime mover in which the direction of travel and its control for field operation is performed by the operator walking behind it. It is also known as Hand tractor or walking type tractor. The concept of power tiller came in the world in the year 1920. Japan is the first country to use power tiller on large scale. In Japan, the first successful model of power tiller was designed in the year 1947. In India power tiller was introduced in the year 1963. Manufacturing of several makes of power tillers like Iseki, Sato, Krishi, Kubota, Yanmar and Mitsubishi were started in India after 1962.

In agricultural power tillers are used for ploughing, sowing, spraying, harvesting and transporting works. It is the most wanted machine for puddling operation in rice cultivation.



Power tiller



Power tiller

Components of power tiller

1. Engine
2. Transmission gears
3. Clutch
4. Brakes
5. Rotary unit

All power tillers are fitted with an I.C. engine. At present makes like Kubota, Mitsubishi, Krishi, Yanmar and Satoh use diesel engine. Iseki make use kerosene engine.

Operation of a power tiller (power transmission in a power tiller)

For operation of power tiller, the power is obtained from the I>C engine, fitted on the power tiller. The engine power goes to the main clutch with the help of belt or chain. From main clutch power is divided in two routes, one goes to transmission gears, steering clutch and the to wheels. The other component goes to the tilling clutch and then to tilling attachment .V - belt pulley is usually used to transmit power from the engine to the main clutch.

Main clutch: Power goes from engine to main clutch through V- belt – pulley arrangement

Transmission gears: Transmission gears consists of gears, shafts, and bearings. Transmission gears reduce speed of the engine and increase the torque at the wheels.

Brakes: All power tillers have braking arrangement for stopping the movement of power tiller.

Wheels: Usually two to four ply pneumatic tyre are used in power tillers for the wheels. The inflation pressure ranges from 1.1 to 1.4 kg/cm².

Rotary unit: Power tillers have a rotary unit for field operation. Rotary tines are used in rotary unit for soil cutting and pulverizing purposes. Rotary tines are of three types

- a) Straight tines
- b) Curved tines
- c) L shape blades

Uses

1. For puddling operation in paddy fields- using rotary tines
2. For cutting and pulverizing the soil in dry lands and in garden lands
3. For cutting and pulverizing the stubbles of sugarcane, maize and cotton
4. For sowing and inter-cultivation works
5. For spraying of orchard trees
6. For transporting purposes



Lecture 05

TILLAGE- OBJECTIVES AND TYPES FURROW TERMINOLOGY AND METHODS OF PLOUGHING. FIELD CAPACITY AND FIELD EFFICIENCY TILLAGE

Mechanical manipulation of soil to provide favorable condition for proper crop growth is called tillage. Soil tillage consists of breaking the compact surface of earth to a certain depth and to loosen the soil mass so as to enable the roots of the crops to penetrate and spread into the soil.

Objectives of Tillage

- To prepare a desirable soil structure for a deep seed bed or a root bed suitable for different types of crops. (A granular structure is desirable to allow rapid infiltration and good retention of rainfall, to provide adequate air capacity and exchange with in the soil and to minimize resistance to root penetration. A good seed bed generally considered to imply finer particles and greater firmness in the vicinity of the seed)
- To control weeds or to remove unwanted crop plants (thinning)
- To manage plant residues. (Mixing of trash is desirable from the tilth and decomposition stand points and retention of trash in the top layers reduce erosion)
- To minimize soil erosion. (By following counter tillage, listing and proper placement of trash).
- To establish specific surface configurations for planting, irrigating, drainage, harvesting operations etc.
- To incorporate and mix fertilizers, pesticides, soil amendments etc. in to the soil

Classification of Tillage

Tillage operations for seed bed preparations are classified as: i) Primary tillage ii) Secondary tillage.

1. Primary tillage:

The initial major soil working operation designed to plough the soil deeply to reduce soil strength, cover plant materials and rearrange aggregates is called primary tillage. The objectives of primary tillage are

- To reduce soil strength
- To rearrange aggregates
- To cover plant materials and burry weeds
- To kill insects and pests

The implements used for primary tillage are called as primary tillage implements. They include many animal drawn and tractor drawn implements. Animal drawn implements mostly include indigenous ploughs and mould-board ploughs. Tractor drawn implements include mould-board ploughs, disc ploughs, heavy duty disk harrows, sub soil ploughs, chisel ploughs and other similar implements.

2. Secondary tillage:

Lighter and finer tillage operations performed in the soil after primary tillage to create proper soil tilt and surface configuration for seeding and planting are called secondary tillage operations. Secondary tillage operations are generally done on the surface soil. They do not cause much soil inversion and shifting of soil from one place to other. They consume less power per unit area compared to primary tillage operations. The main objectives of secondary tillage are

- To break the big clods and make the soil surface uniform and leveled as needed for a seed bed
- To destroy grasses and weeds in the field.
- To cut crop residues and mix them with top soil

The implements used for secondary tillage operations are called secondary tillage implements. They include different types of harrow, cultivators, sweeps, clod crushers, levellers, bund formers, ridge ploughs etc.

TILLAGE SYSTEMS

Tillage system consists of sequences of operations that manipulate the soil in order to produce a crop. The operations include tilling, planting, fertilization, pesticide application, harvesting, and residue chopping or shredding. The ways in which these operations are implemented affect the physical and chemical properties of the soil, which in turn affect plant growth. There are two types of tillage systems namely a) conservation tillage system including no-till, ridge till and mulch till systems and b) other than conservation tillage systems namely a) reduced tillage system and b) conventional tillage system.

Conservation tillage (30 percent or more crop residue left after planting)

Any tillage and planting system that covers 30 percent or more of the soil surface with crop residue, after planting, to reduce soil erosion by water or any system that maintains at least 1,120 kilogram per hectare of flat, small grain residue equivalent on the surface throughout the critical wind erosion period is called conservation tillage system. Conservation tillage systems are further classified as a) no-till, b) ridge-till, and c) mulch-till. Systems

1. No-till: No-till is defined as a system in which the soil is left undisturbed from harvest to planting except for nutrient injection. Planting or drilling is accomplished in a narrow seedbed or slot created by coulters, row cleaners, disk openers, in-row chisels, or roto-tillers. Weed

control is accomplished primarily with herbicides. Cultivation may be used for emergency weed control.

2. Ridge-till: In ridge-till, the soil is also left undisturbed from harvest to planting except for nutrient injection. Planting is completed in a seedbed prepared on ridges with sweeps, disk openers, coulters, or row cleaners. Residue is left on the surface between ridges. Weed control is accomplished with herbicides and/or cultivation. Ridges are rebuilt during cultivation.

3. Mulch-till: The soil is disturbed before planting. Tillage tools such as chisels, field cultivators, disks, sweeps or blades are used. Weed control is accomplished with herbicides and/or cultivation. Mulch-till is a category that includes all conservation tillage practices other than no-till and ridge-till. Two tillage practices that fall into this category are zone-till and strip-till. Both of these tillage practices involve tilling a strip into which seed and fertilizer are placed.

Other tillage systems (less than 30 percent crop residue left after planting)

Tillage systems that leave less than 30 percent crop residue after planting are not classified as conservation tillage. However, these systems may meet erosion control goals with or without other supporting conservation practices, such as strip cropping, contouring, terracing, etc.

1) Reduced-till: Reduced-till systems leave 15-30 percent residue cover after planting or 560 to 1,120 kilograms per hectare of small grain residue equivalent throughout the critical wind erosion period.

2) Conventional-till: Conventional-till systems leave less than 15 percent residue cover after planting, or less than 560 kilograms per hectare of small grain residue equivalent throughout the critical wind erosion period. These systems generally involve plowing or some other form of intensive tillage.

ANOTHER CLASSIFICATION OF TILLAGE SYSTEMS

There are two types of tillage namely a. Conventional tillage or clean tillage and b. Conservation tillage

1. Conventional tillage or clean tillage: Ploughing the entire field several times to prepare a seed bed is called conventional tillage

2. Conservation tillage: Ploughing the field with lesser number of passes over the entire land or ploughing only in the required space of the land and then sowing is called conservation tillage. . Different types of conservation tillage are as follows

a. Minimum Tillage -Minimum soil manipulation necessary to meet tillage requirements



Minimum Tillage for Wheat

b. Mulch Tillage - Tillage operations in which nearly 30 % of crop residue or other mulching materials are left on or near the soil surface is called mulch tillage.



Farm Waste Mulching

Mulch tillage

c. Rotary Tillage for crop production is called minimum tillage.

d. Strip Tillage - In strip tillage system only isolated bands of soil are tilled.- Tillage operations employing rotary action of the tool to cut, break and mix the soil is called rotary tillage..



Strip tillage in wheat



Strip tillage in corn



Strip till in wheat

e. Combined Tillage – Tillage operations utilizing simultaneously two or more different types of tillage tools or implements to simplify, control or reduce the number of operations over a field is called combined tillage.

PLOUGHING OF LAND:

Ploughing of land separates the top layer of soil into furrow slices. The furrows are turned sideways and inverted to a varying degree, depending upon the type of plough being used. It is a primary tillage operation, which is performed to shatter soil uniformly with partial or complete soil inversion.

Furrow terminologies

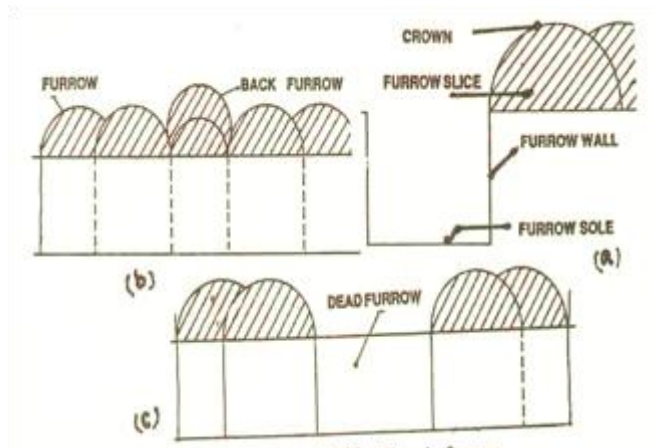

Fig.1. Plough furrow

There are a few important terms frequently used in connection with ploughing of a land.

(i) Furrow: It is a trench formed by an implement in the soil during the field operation (Fig.1a).

(ii) Furrow slice: The mass of soil cut, lifted and thrown to one side is called furrow slice.

(iii) Furrow wall: It is an undisturbed soil surface by the side of a furrow.

(iv) Crown: The top portion of the turned furrow slice is called crown.

(v) Back furrow: A raised ridge left at the centre of the strip of land when ploughing is started from centre to side is called back furrow. When the ploughing is started in the middle of a field, furrow is collected across the field and while returning trip another furrow slice is

lapped over the first furrow. This is the raised ridge which is named as back furrow (Fig.1b).

(vi) **Dead furrow:** An open trench left in between two adjacent strips of land after finishing ploughing is called dead furrow (Fig.1c).

(vii) **Head land:** While ploughing a land with a tractor a strip of unploughed land is left at each end of the field for the tractor to turn, which is called head land. At the end of each trip, the plough is lifted until the tractor and the plough have turned and are in position to start the return trip. The head land is about 6 meters wide for two or three bottom tractor plough and one meter more for each additional bottom.

METHODS OF PLOUGHING A LAND

There are two main methods of ploughing a field which are known as “inlands” and “round about” ploughing

A normal right hand plough must always have an open furrow on the right in which to lay the next furrow slice. It is therefore, necessary to travel across the field in one place and come back in another. There are two ways of doing this by “gathering” and “casting”

Gathering:

Whenever a plough works round a strip of ploughed land, it is said to be gathering. The tractor and plough turns to right each time the head land is reached. When the land is ploughed, a raised ridge (double width ridge) is formed in the center of the field. This however would be uneconomical way of working as time is wasted at the start in making awkward turns, while later, total idle running would be increased along the head land

Casting:

Whenever a plough works round a strip of un ploughed land, it is said to be casting. The tractor and plough turns to the left each time the head land is reached. When the land is ploughed in this way a wide furrow (double width furrow) will be left in the center and is termed as ‘finish’ or open furrow or dead furrow

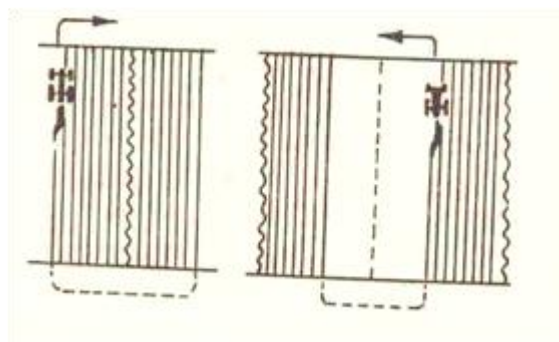

a.. Gathering

b. Casting

It is recommended that long field should be ploughed by gathering in one season and casting in another season. It avoids building up of a ridge in the centre and an open furrow at each side or vice versa. However, ploughing of a field either by casting or by gathering alone is normally uneconomical. For economical ploughing the following methods are used.

a) Continuous ploughing method

In normal conditions, the continuous ploughing method is considered very convenient and economical. This is a method usually used in which the tractor and plough never run idle for more than three quarter land width along the headland and never turn in a space narrower than a quarter land width. In this method, first the headland is marked and the first ridge is set up at three quarter of a land width from the side (Fig. a). The other ridges are set at full width over the field. The operator starts ploughing between the first ridge and the side land. The operator continues to turn left and cast in the three quarter land until ploughing is completed in a quarter land width on each side (Fig. b). At this stage, the plough is lifted to half depth for the last trip down the side land of the field. This leaves a shallow furrow where the finish comes.

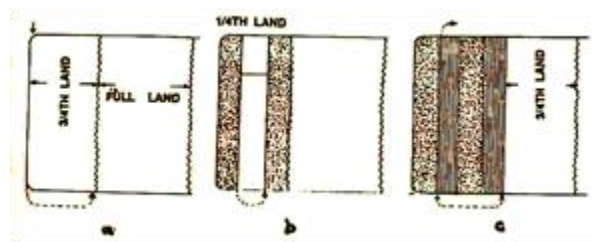

Continuous ploughing method

After this stage, the driver turns right and gathers round the one fourth land already ploughed. Gathering is continued till the un ploughed strip in first three-quarter land is ploughed and completed. This gathering reduces the first full land by a quarter (Fig. c). The remaining three quarter land can be treated in exactly the same manner as the original three quarter land completed earlier. This process is repeated for all other lands in the field.

b) Round and round ploughing

In this method, the plough moves round and round in a field. This system is adopted under conditions where ridges and furrows interfere with cultivation work. The field can be started in two ways.

a) Starting at the centre

A small plot of land is marked in the middle of the field and it is ploughed first. After that, the plough works round this small plot and the entire plot is completed. This is not a very economical method.

b) Starting at the outer end

Tractor starts ploughing at one end of the field and then moves on all the sides of the field and comes gradually from the sides to the centre of the field. Wide diagonals are left unploughed to avoid turning with the plough. There are no back furrows in this method. Conventional ploughing is usually done by this method.

c) One way ploughing

This system requires the use of a special type of plough known as reversible plough or one way plough. Such a plough turns furrows to the left or right. After the head land has been marked, the operator plough along a straight side land mark. At the end of the first trip, he turns his tractor in a loop and returns down the same furrow. No dead and back furrows are left in the field. In gently sloping fields, this method is suitable.

FIELD PERFORMANCE OF MACHINES

The rate at which a machine can cover a field while performing its intended function is one of the considerations in determining the cost of operation of the machine

Theoretical field capacity

It is the rate of field coverage that would be obtained if the machine were performing its function 100 % of the time at the rated forward speed and always covering 100 % of its rated width,

$$\text{Theoretical field capacity FCT} = \frac{\text{width (cm)} \times \text{speed (metre / sec)} \times 36}{10000} \text{ ha / h}$$

Another equation

$$\text{Theoretical field capacity FCT} = \frac{SW}{10} \text{ ha / h}$$

Where

FCT = effective field capacity, hectare per hr.

S = speed of travel in km per hour.

W = theoretical width of cut of the machine in metre, and

Theoretical time per hectare

It is the time that would be required at the theoretical field capacity

Effective operating time

It is the time during which the machine is actually performing its intended function. The effective operating time per hectare is greater than the theoretical time per hectare if less than full rated width is utilized

Effective field capacity

It is the actual coverage of the machine based on the total field time. Effective field capacity is usually expressed as hectares per hour

Field efficiency

It is the ratio of effective field capacity to theoretical field capacity expressed as percent.

$$\text{Field efficiency} = \frac{\text{Effective field capacity}}{\text{Theoretical field capacity}} \times 100$$

Effective field capacity is calculated as follows

$$\text{FCA} = \frac{S \times W}{10} \times \frac{E}{100} \text{ ha/h}$$

Where

FCA = effective field capacity, hectare per hr.

S = speed of travel in km per hour.

W = theoretical width of cut of the machine in metre, and

E = field efficiency in per cent.

$$\text{Soil inversion} = \frac{\text{No. of weeds seen on the surface after ploughing in the same area}}{\text{No. of weeds seen on the surface before ploughing in an area}} \times 100$$

Soil pulverization

It is the quality of work performed by a plough expressed in terms of particle size distribution.

It is determined by sieve analysis.

PROBLEMS ON FIELD CAPACITY AND FIELD EFFICIENCY OF TILLAGE IMPLEMENTS

Theoretical field capacity

It is the rate of field coverage of the implement, based on 100 per cent of time at the rated speed and covering 100 per cent of its rated width.

$$\text{Theoretical field capacity in hectares / hr} = \frac{\text{width (cm)} \times \text{speed (metre / sec)} \times 36}{10000}$$

Effective field capacity

It is the actual area covered by the implement based on its total time consumed and its width.

Field efficiency

It is the ratio of effective field capacity and theoretical field capacity expressed in percent.

$$\text{Field efficiency} = \frac{\text{Effective field capacity}}{\text{Theoretical field capacity}} \times 100$$

Effective field capacity is calculated as follows

$$C = \frac{S \times W \times E}{10 \times 100}$$

Where

C = effective field capacity, hectare per hr.

S = speed of travel in km per hour.

W = theoretical width of cut of the machine in metre, and

E = field efficiency in per cent.

Problem.1. A 5 x 20 cm double action disc harrow is operated by a tractor having a speed of 5 km/h. Calculate the actual field capacity, assuming the field efficiency of 80 percent.

Solution:

Size of the harrow (width) = 5 x 20 = 100 cm

$$\text{Area of coverage} = \frac{S \times W \times E}{10 \times 100}$$

$$= (1 \times 5 \times 80) / 1000$$
$$= 0.4 \text{ ha/h}$$

Problem 2: A 3 x 30 cm plough is moving at a speed of 4 km/h. calculate how much time it take to plough 500 x 500 m field when the field efficiency is 70 %.

Solution:

$$\text{Width of the plough} = 3 \times 30 = 90 \text{ cm} = 0.9 \text{ m}$$

$$\text{Effective field capacity} = (0.9 \times 4 \times 70) / 1000$$
$$= 0.25 \text{ ha/h} = 2500 \text{ m}^2/\text{h}$$

$$\text{Time required} = 500 \times 500 / 2500$$

$$= 100 \text{ h}$$

Problem 3: A 4 bottom 40 cm mould board plough is operating at 5.5 km/h speed with 75 % field efficiency. Calculate what is the rate of doing work in hectares per hour.

Solution:

$$\text{Width of the plough} = 4 \times 40 = 160 \text{ cm} = 1.6 \text{ m}$$

$$\text{Area covered} = 1.6 \times 5.5 \times 75 / 1000$$
$$= 0.66 \text{ ha/h}$$

Problem 4: An indigenous plough has a 20 cm wide furrow at the top and 10 cm depth. Calculate the volume of soil handled per day 8 hours if the speed of working is 2.5 km/h.

Solution:

$$\text{Furrow cross section} = 10 \times 20 / 2$$

$$= 100 \text{ cm}^2$$

$$\text{Distance traveled in 8 hours} = 8 \times 2.5 \times 1000 = 20,000 \text{ m}$$

$$\text{Volume of soil handled} = 20000 \times 100 / 10000$$
$$= 200 \text{ m}^3$$

Model questions

- A three bottom 40 cm M.B plough is working at a speed of 4 km/h . Calculate the effective field capacity if the field efficiency is 80 percent.
- A four bottom 30 cm M.B plough is working at a speed of 4.5 km/h. Calculate the actual field capacity if the field efficiency is 70 percent.

MODEL QUESTIONS

- List the animal drawn primary tillage implements .

- iii. Define Theoretical field capacity.
 - iv. Define Effective field capacity.
 - v. Define field efficiency
 - vi. List the objectives of Tillage
 - Differentiate casting and gathering.
 - With neat diagram mention the furrow terminologies
 - What do you mean by soil pulverization?
 - Define conservation tillage
 - Define mulch tillage
1. Preparation of soil in such a way that crop residues and other mulching materials are left on the surface is called
 - a. minimum tillage
 - b. strip tillage
 - c. rotary tillage
 - d. mulch tillage
 2. The open trench left in between two adjacent strips of land after finishing the ploughing is called
 - a. dead furrow
 - b. back furrow
 - c. head land
 - d. crown
 3. Theoretical field capacity of a double action disc harrow is 1.0 ha/h. Field efficiency is 80 %. What is the actual field capacity?
 - a. 1.0 ha/h
 - b. 1.5 ha/h
 - c. 0.5 ha/h
 - d. 0.8 ha/h
 4. Soil tillage consists of breaking compact surface of soil to certain depth and loosening the soil True / False
 5. Whenever a plough works round a strip of unploughed land it is called casting True / False
 6. When a plough works round a strip of ploughed land it is called as Casting True / False



Lecture 06

PRIMARY TILLAGE - OBJECTIVES, MOULD BOARD PLOUGH , DISC PLOUGH, CHISEL PLOUGH, SUBSOILER , COMPONENTS AND FUNCTIONS, TYPES, ADVANTAGES AND DISADVANTAGES

PRIMARY TILLAGE:

The initial major soil working operation designed to plough the soil deeply to reduce soil strength, cover plant materials and rearrange aggregates is called primary tillage.

Objectives of primary tillage

- To reduce soil strength
- To rearrange aggregates
- To cover plant materials and burry weeds
- To kill insects and pests

The implements used for primary tillage are called as primary tillage implements. They include many animal drawn and tractor drawn implements. Animal drawn implements mostly include indigenous ploughs and mould-board ploughs. Tractor drawn implements include mould-board ploughs, disc ploughs, heavy duty disk harrows, subsoil ploughs, chisel ploughs and other similar implements.

PLOUGH

The main implement used for primary tillage is a plough. Ploughing essentially consists of opening the upper crust of the soil, breaking the clods and making the soil suitable for sowing seeds. The purpose of ploughing can be summarized as follows

- To obtain a deep seed bed of good texture.
- To increase the water holding capacity of the soil.
- To improve soil aeration.
- To destroy weeds and grasses.
- To destroy insects and pests.
- To prevent soil erosion and
- To add fertility to the soil by covering vegetation.

Classification of ploughs according to power used

- Bullock drawn ploughs- indigenous types

ii) Walking type

- Short beam
- Long beam

ii) Riding type

- Tractor drawn ploughs
- mounted type
- Semi mounted type

INDIGENOUS PLOUGH

It is an animal drawn plough. It penetrates into the soil and breaks it open. It forms V shaped furrows with 15-20 cm top width and 12-15 cm depth. It can be used for ploughing in dry land, garden land and wetlands. The size of the plough is represented by the width of the body and the field capacity is around 0.4 ha per day of 8 hours. The functional components include share, body, shoe, handle and beam. Except share all other parts are made up of wood. In villages local artisans make the plough and supply to the farmers. These ploughs are also called as country ploughs.

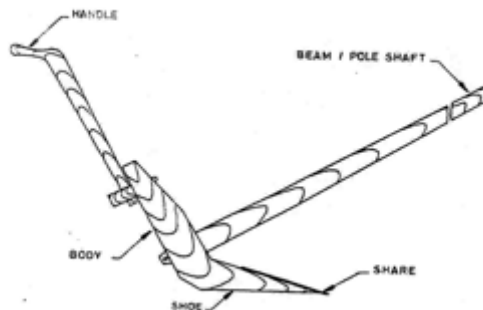

Indigenous plough

Share - It is the working part of the plough attached to the shoe with which it penetrates into the soil and breaks it open.

Shoe - It supports and stabilizes the plough at the required depth.

Body - It is the main part of the plough to which the shoe, beam and handle are attached. In country ploughs both body and shoe are made in a single piece of wood..

Beam - It is a long wooden piece, which connects the main body of the plough to the yoke.

Handle - A wooden piece vertically attached to the body to enable the operator to control the plough while it is working

In each state farmers use indigenous ploughs of their own make.

Operational adjustments

- a. Lowering or raising the free end of the beam with respect to the plough body results in an increase or decrease in the share angle with respect to the horizontal surface which in turn increase or decrease the depth of ploughing.
- b. Changing the length of the beam between plough body and yoke of the animals will also alter the depth of ploughing. Reducing the beam length will decrease the depth of cut and vice versa.

MOULD BOARD PLOUGH

Moldboard plough is one of the oldest of all agricultural implements and is generally considered to be the important tillage implement. Ploughing accounts for more traction energy than any other field operation. Mouldboard ploughs are available for animals, power tiller and tractor operation. While working, a mouldboard plough does four jobs namely a) cutting the furrow slice b) lifting the furrow slice c) inverting the furrow slice and d) pulverizing the furrow slice.



Two bottom mouldboard plough



Tractor with two bottom mouldboard plough



Land ploughed by a mouldboard plough

COMPONENTS OF A MOULDBOARD PLOUGH

A animal drawn mouldboard plough consists of a) plough bottom b) beam and c) hitch bracket or clevis. A tractor drawn mouldboard plough consists of a) plough bottom b) beam or standard c) main frame and d) hitch frame

a) Plough bottom – The part of the plough which actually cuts, lifts, pulverizes and through the soil out of the furrow. It is composed of those parts necessary for the rigid structure required to cut, lift, turn, and invert the soil. Parts of the mouldboard plough bottom are a) Share b) Mould board c) Land side d) Frog and e) Tail piece. Share, landside, mouldboard are bolted to the frog which is an irregular piece of cast iron.

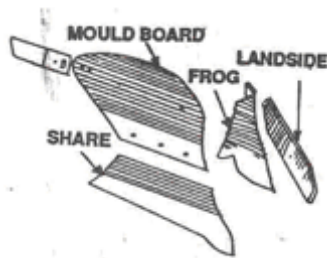

Components of Mould Board plough

b) Share: It is that part of the plough bottom which penetrates into the soil and makes a horizontal cut below the surface.

c) Mould board: It is the curved part which lifts, turns, and pulverizes the soil slice.

d) Land side: It is the flat plate which presses against the furrow wall and prevents the plough from lateral swinging. The rear part of land side is called heel which slides on the bottom of the furrow.

e) Frog: It is the part to which share, land side and mouldboard are attached.

f) **Tail piece:** It is an adjustable extension, which can be fastened to the rear of the mould board to help in turning the furrow slice.

DETAILS ABOUT DIFFERENT COMPONENTS OF MOULDBOARD PLOUGH

1. **Share** - It penetrates into the soil and makes a horizontal cut below the soil surface . It is a sharp, well polished and pointed component. Different portions of the share are called by different names such as

- 1) Share point
- 2) Cutting edge
- 3) Wing of share
- 4) Gunnel
- 5) Cleavage edge
- 6) Wing bearing.

Share

- **Share point :** It is the forward end of the cutting edge which actually penetrates into the soil
- **Cutting edge:** It is the front edge of the share which makes horizontal cut in the soil. It is beveled to some distance.
- **Wing of share:** It is the outer end of the cutting edge of the share. It supports the plough bottom
- **Gunnel:** It is the vertical face of the share which slides along the furrow wall. It takes the side thrust of the soil and supports the plough bottom against the furrow wall .
- **Cleavage edge:** It is the edge of the share which forms joint between mouldboard and share on the frog.
- **Wing bearing:** It is the level portion of the wing of the share, providing a bearing for the outer corner of the plough bottom.

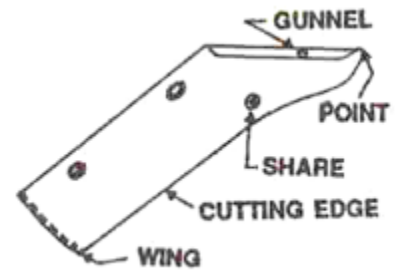

Material of share: The shares are made of chilled cast iron or steel. The steel mainly contains about 0.70 to 0.80% carbon and about 0.50 to 0.80% manganese besides other minor elements.

2. Types of Shares

Share is of different types such as i) Slip share ii) Slip nose share iii) Shin share and iv) Bar point share.

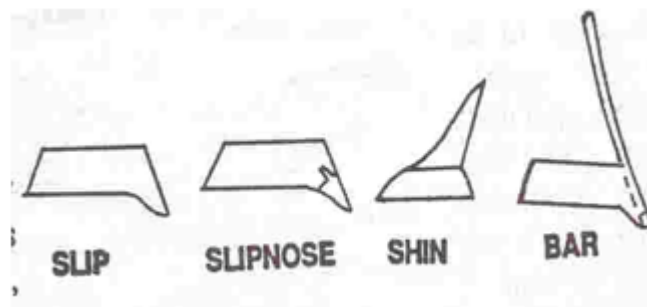

Types of shares

i) Slip share: It is one piece share with curved cutting edge, having no additional part. It is a common type of share, mostly used by the farmers. It is simple in design, but it has got the disadvantage that the entire share has to be replaced if it is worn out due to constant use.

ii) Slip nose share: It is a share in which the point of share is provided by a small detachable piece. It has the advantage that the share point can be replaced as and when required. If the point is worn out, it can be changed with a new nose without replacing the entire share, effecting considerable economy.

iii) Shin share: It is the share having a shin as an additional part. It is similar to the slip share with the difference that an extension is provided to it by the side of the mouldboard.

iv) Bar point share: It is the share in which the point of the share is provided by an adjustable and replaceable iron bar. This bar serves the purpose of share point and land side of the plough.

3. Mouldboard: It is that part of the plough which receives the furrow slice from the share. It lifts, turns and breaks the furrow slice. To suit different soil conditions and crop requirements, mouldboard has been designed in different shapes. The mouldboard is of following types: a) General purpose b) Stubble type c) Sod or Breaker type and d) Slat type.

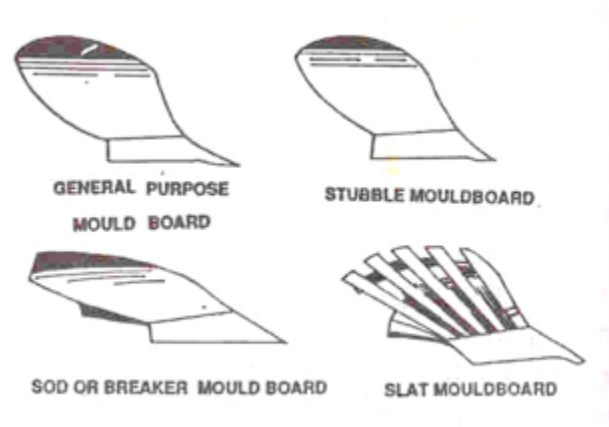

Types of mould board

a) General purpose: It is a mouldboard having medium curvature lying between stubble and sod types. The mouldboard is fairly long with a gradual twist, the surface being slightly convex. The sloping of the surface is gradual. It turns a well defined furrow slice and pulverizes the soil thoroughly.

b) Stubble type: It is short but broader mouldboard with a relatively abrupt curvature which lifts, breaks and turns the furrow slice. This is best suited to work in stubble soil that is under

cultivation for years together. Stubble soil is that soil in which stubble of the plants from the previous crop is still left on the land at the time of ploughing. This type of mouldboard is not suitable for lands with full of grasses.

c) Sod or Breaker type: It is a long mould board with gentle curvature which lifts and inverts the unbroken furrow slice.. It turns over thickly covered soil. This is very useful where complete inversion of soil is required by the farmer. This type has been designed for used in sod soils (soil with much of grass).

d) Slat type: It is a mouldboard whose surface is made of slats placed along the length of the mouldboard, so that there are gaps between the slats. This type of mouldboard is often used, where the soil is sticky, because the solid mouldboard does not scour well in sticky soils.

4) Land side: It is the flat plate which presses against and transmits lateral thrust of the plough bottom to the furrow wall (Fig.6). It helps to resist the side pressure exerted by the furrow slice on the mouldboard. It also helps in stabilizing the plough while in operations. Land side is fastened to the frog with the help of plough bolts. The rear bottom end of the land side is known as **heel** which rubs against the furrow sole.

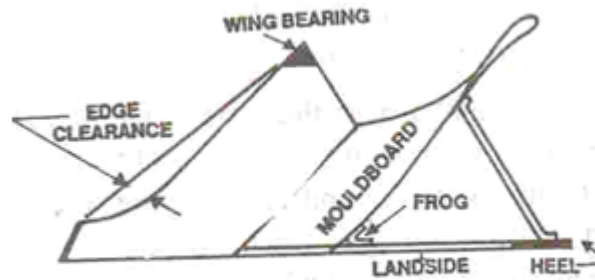

Mould board bottom

5) Frog: Frog is that part of the plough bottom to which the other components of the plough bottom are attached. It is an irregular piece of metal. It is made of cast iron for cast iron ploughs or it may be welded steel for steel ploughs.

6) Tail piece: It is an important extension of mouldboard which helps in turning a furrow slice.

PLOUGH ACCESSORIES

There are a few accessories necessary for efficient function of the plough. They are (i) Jointer (ii) Coulter (iii) Gauge wheel (iv) Land wheel and (v) Furrow wheel.

a) Jointer

It is a small irregular piece of metal having a shape similar to an ordinary plough bottom. It looks like a miniature plough. Its purpose is to turn over a small ribbon like furrow slice directly in front of the main plough bottom. This small furrow slice is cut from the left and upper side of the main furrow slice and is inverted so that all trashes on the top of the soil are completely turned down and buried under the right hand corner of the furrow.

b) Coulter

It is a device used to cut the furrow slice vertically from the land ahead of the plough bottom. It cuts the furrow slice from the land and leaves a clear wall. It also cuts trashes which are covered under the soil by the plough. The coulter may be (a) Rolling type disc coulter or (b) Sliding type knife coulter.

Rolling type disc coulter

It is a round steel disk which has been sharpened on the edge and suspended on a shank and yoke from the beam. The edge of the coulter may be either smooth or notched. It is so fitted that it can be adjusted up-down and side ways. The up-down adjustment takes care of depth and sideways adjustment is meant for taking care of width of cut.

Sliding type knife coulter

It is a stationary knife fixed downward in a vertical position on the beam. The knife does not roll over the ground but slides on the ground. The knife may be of different shapes and sizes.

c) Gauge wheel

It is an auxiliary wheel of an implement to maintain an uniform depth of working. Gauge wheel helps to maintain uniformity in respect of depth of ploughing in different soil conditions. It is usually placed in hanging position.

d) Land wheel - It is the wheel of the plough which runs on the ploughed land.

e) Front furrow wheel - It is the front wheel of the plough which runs in the furrow.

f) Rear furrow wheel - It is the rear wheel of the plough which runs in the furrow.

ADJUSTMENT OF MOULDBOARD PLOUGH

For proper penetration and efficient work by the mouldboard plough, some adjustments are made from time to time. They are (i) Vertical suction and (ii) Horizontal suction.

a) Vertical suction (Vertical clearance)

It is the maximum clearance under the land side and the horizontal surface when the plough is resting on a horizontal surface in the working position. It is also defined as the vertical distance from the ground, measured at the joining point of share and land side. (Fig.7a). It helps the plough to penetrate into the soil to a proper depth. This clearance varies according to the size of the plough.

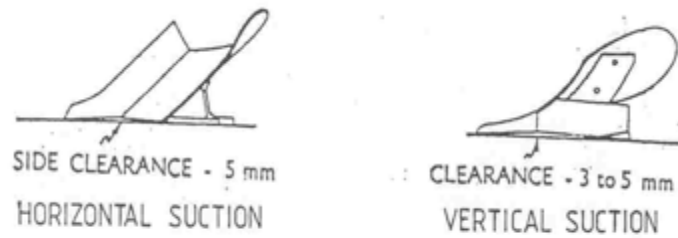

Vertical clearance horizontal clearances

b) Horizontal suction (Horizontal clearance)

It is the maximum clearance between the land side and the furrow wall. This suction helps the plough to cut the proper width of furrow slice. This clearance also varies according to the size of the plough. It is also known as side clearance.

c) Throat clearance

It is the perpendicular distance between share point and lower position of the beam of the plough.

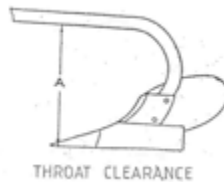

Throat clearance of plough

TYPES OF MOULDBOARD PLOUGHS

- **Fixed type (one way) mouldboard plough**

One way plough throws the furrow slice to one side of the direction of travel and is commonly used everywhere. It may be long beam type or short beam type

2) Two-way or Reversible plough

It is a mouldboard plough which turns furrow slice to the right or left side of direction of travel as required. Such ploughs have two sets of opposed bottoms. In such a plough, all furrows can be turned towards the same side of the field by using one bottom for one direction of travel and the other bottom on the return trip. Two sets of bottom are so mounted that they can be raised or lowered independently or rotated along an axis. Two way ploughs have the advantage that they neither upset the slope of the land nor leave dead furrows or back furrows in the middle of the field.

3) Turn wrest plough

There are some reversible ploughs which have single bottom with an arrangement that the plough bottom is changed from right hand to left hand or vice versa by rotating the bottom through approximately 180° about a longitudinal axis. This type of plough is called turn wrest plough. While moving in one direction, the plough throws the soil in one direction and at the return trip the direction of the plough bottom is changed, thus the plough starts throwing the soil in the same direction as before.

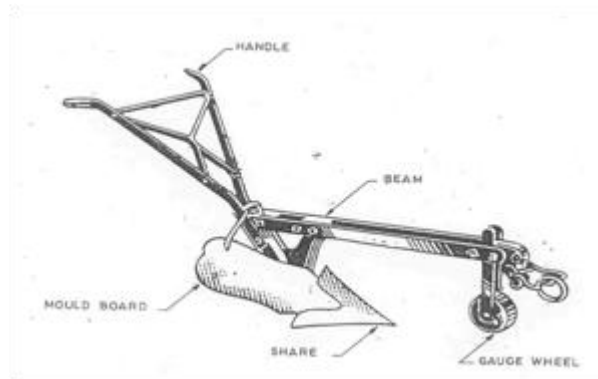

Turn wrest plough

OTHER TERMS CONNECTED WITH PLOUGHS

a) Vertical clevis

It is a vertical plate with a number of holes and fitted at the end of the beam. By using the clevis depth of operation and line of pull are adjusted.

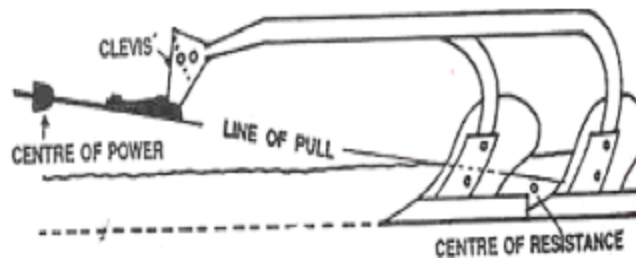

Clevis and line of pull

***** 😊 *****

Lecture 07

SECONDARY TILLAGE EQUIPMENT - HARROWS, LAND FORMING EQUIPMENT - ROTAVATORS - WET LAND EQUIPMENT - PUDDLERS AND MANURE TRAMPLERS - CAGE WHEELS

SECONDARY TILLAGE

Tillage operations performed after primary tillage to create proper soil tilth for seeding and planting are called secondary tillage. These operations are lighter and finer operations performed on the soil after primary tillage operations. Secondary tillage operations do not cause much soil inversion and shifting of soil from one place to another place. These operations consume less power per unit area compared to primary tillage operations. The implements used for secondary tillage operations are called secondary tillage implements they include different types of harrows, rollers and pulverizers, rotary tillers, tools for mulching and fallowing, cage wheels etc.

The objectives of secondary tillage

1. To improve the seed bed by greater pulverization of the soil
2. To destroy grasses and weed seeds in the field.
3. To cut crop residues and mix them with top soil
4. To break the big clods and to make the field surface uniform and leveled.

HARROWS

Harrow is a secondary tillage implement used for a variety of jobs in crop cultivation. They are listed as follows

1. Used before ploughing to cut vegetable matter such as corn stock, cotton stalk, and weeds and mix with soil for soil conservation
2. Used to pulverize the top soil so that the furrow slices will make better connection with the bottom of the sole preventing air space when slices are turned
3. Used after ploughing to pulverize the soil and put it in better tilth for the reception of the seed
4. Used for the cultivation of crops
5. Used for summer fallowing
6. Used to cover the seeds after sowing

There are many kinds of harrows namely, the disc harrow, spike tooth harrow, spring tooth harrow, rotary cross-harrow, soil surgeon, triangular harrow, acme harrow, blade harrow, reciprocating power harrow etc.

DISC HARROW

It is a harrow, which performs the harrowing operation by means of a set of rotating discs, each set being mounted on a common shaft. Disc harrow is found very suitable for hard ground with full of stalks and grasses. It cuts the lumps of soil, clods and roots. Discs are mounted on one, two or more axles which may be set at a variable angle to the line of motion. As the harrow is pulled ahead, the discs rotate on the ground. Depending upon the disc arrangements, disc harrows are divided into two classes a) Single action and b) Double action.

1. SINGLE ACTION DISC HARROW

It is a harrow with two gangs placed end to end with an angle greater than 90°. The discs are arranged in opposite directions on both gangs so that the right side gang throws the soil towards right and the left side gang throws the soil towards left.

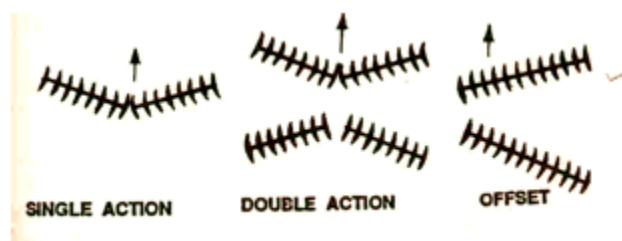

Types of disc harrow

2. DOUBLE ACTION DISC HARROW (TANDEM DISC HARROW)

The double action disc harrow is often called a tandem harrow because a set of two gangs follows behind the front gangs and is arranged in such a way that the discs on the front gangs throw the soil in one direction (usually outward) , and the discs on the rear gangs throw the soil in the opposite direction (outward) Thus the entire field is worked twice in each trip



3. OFF-SET DISC HARROW-

Offset disk harrow has one right-hand gang (throwing the soil to the right) and one left – hand gang (throwing the soil to the left), operating in tandem. The harrow is given this name because the harrow can be operated in offset position in relation to the tractor. A change in hitch can cause the harrow to run either to the left or right of the tractor. It is possible to operate the harrow under limbs, near trees in an orchard.

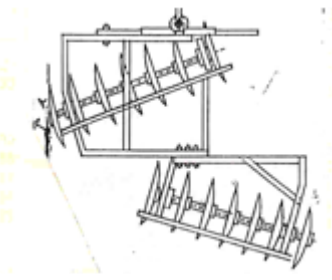

Offset disc harrow

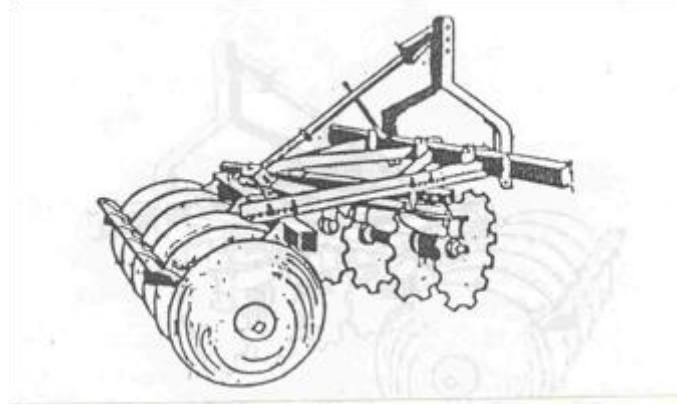

Fig.4. Disc harrow

PARTS OF A DISC HARROW

i. Disc: It is a circular concave disc which cuts and inverts the soil. Disc is made of heat-treated hardened steel. Tractor drawn disc harrows have concave discs of size varying from 35-70 cm diameter. Concavity of the disc affects penetration and pulverization of soil. Usually two types of disc are used in disc harrows, plain disc and cut away disc. Plain discs have plain edges and they are used for all normal works. Most of the harrows are fitted with plain discs only. Cut away discs have serrated edges and they cut stalks, grass and other vegetation. They are not effective for pulverization of soil but it is very useful for puddling the field especially for paddy cultivation.

ii. Gang: Each set of discs that are mounted on a common shaft is called the gang.

iii. Gang bolt or arbor bolt: It is a long heavy square headed bolt. Discs are mounted on the gang bolt. The spacing between the discs on the gang bolt ranges from 15 to 25 cm for light duty and 25 to 30 cm for heavy duty harrows.

iv. Gang angle- The angle between the axis of the gang bolt and the direction of travel is called the gang angle.

v. Gang control lever: This lever is used to change the gang angle of the gangs which in turn alters the width of operation.

vi. Spool or spacer: The flanged tube, mounted on the gang bolt between every two discs to prevent the lateral movement of the disc on the shaft is called the 'spool' or 'spacer'. Spacer keeps the discs at equal spacing on the gang bolt. It is usually cast in special shapes and sizes and is generally made of cast iron.

vii. Bearing: Bearing is essential for frictionless rotation of the gang. They also counter act the end thrust due to soil reaction on the discs. Chilled cast iron bearings are used which are more durable than other types of bearings

viii. Transport wheel: In trailing type disc harrows, transport wheels are provided for transport of the harrow on roads without damage to the edges of the discs . Mounted type harrows do not require wheels for transport work.

ix. Scraper: It removes the soil that may stick to the concave side of the disc while working and thus prevents clogging of the discs.

x. Weight box: A box like frame is provided on the main frame of the harrow for putting additional weight on the implement to increase the penetration of the disc in the soil.

ADJUSTMENTS FOR OBTAINING HIGHER PENETRATION

There are several factors which affect the penetration of disc harrow in the field. Penetration can be increased by

1. increasing the gang angle
2. adding weights
3. lowering the hitch point
4. using sharp edged discs of small diameter and lesser concavity
5. regulating the speed.(penetration is better in low speeds than in high speeds)

SPIKE TOOTH HARROW

Spike tooth harrow has teeth resembling long spikes that stir the soil. These harrows are also known as peg tooth harrow, drag harrow, section harrow, or smoothing harrow. Its principal use is to smoothen and level the soil directly after ploughing. It will stir the soil to a depth of about 5 cm, if weighted. It may be used to cultivate corn, cotton and other row crops in early stages of growth. The sections range in width from 1.2 to 1.7m and may have twenty five, thirty, thirty five teeth. Several sections may be attached to a hitch bar and a wide swath harrowed. The sections may be rigid or flexible. Sections that have guard rails across the ends of the bars are called close-end harrows, while those that do not have guard rails are called open-end harrows

ANIMAL DRAWN SPIKE TOOTH HARROW

The animal drawn spike tooth harrow is usually of rigid type. These may or may not have provisions for changing the angle of spikes in operating conditions. This harrow mainly consists of teeth, tooth bar, guard rail, clamps, braces, levers and draft hooks. The teeth are made up of hardened steel with square/ triangular/ circular in section. The teeth are so placed on tooth bar that no tooth is directly behind the other. Teeth are fastened rigidly to the tooth bar. Clamps are rigidly fixed so as not to be loose while in operation.

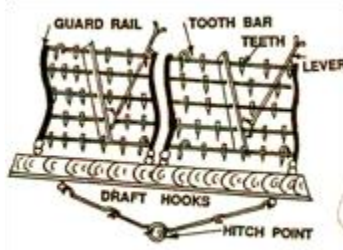

Spike tooth harrow - animal drawn

SPRING TOOTH HARROW

Spring tooth harrows are made in sections somewhat like spike tooth harrows. The sections vary in width from 0.9 to 1.7m. The sections may have from seven to twelve teeth. A single section may be used alone or several sections may be hitched together and used as a unit. The number of sections used depends upon the power available.

The teeth consists of wide, flat, curved, oil-tempered bars of spring steel, one end of which is fastened rigidly to a bar; the other end is pointed to give good penetration. The depth to which the teeth will penetrate the soil is controlled by adjusting the angle of the teeth by means of levers. Some spring tooth harrows are provided with a power - angling hitch.



Spring tooth harrows are adapted for use in rough and stony ground. They are also used extensively to loosen previously ploughed soil ahead of grain drill seeding rice or small grains. The teeth will penetrate deeper than those on spike tooth harrow, and they will give when obstructions are struck. Spring tooth harrow is also called as **quack grass**, and **Bermuda grass eradicator**, since the teeth penetrate deeply, tear out and bring the roots to the surface. Spring tooth harrows are available for animal and tractor operation

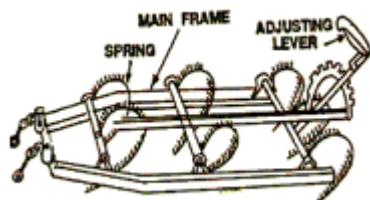

Tractor drawn spring tooth harrow

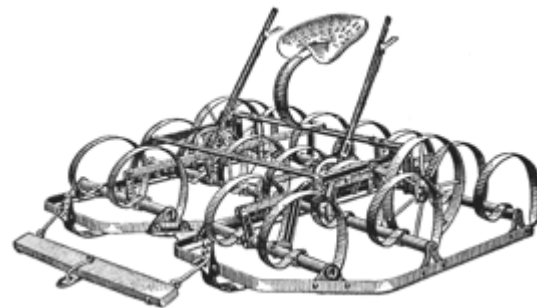

Animal drawn spring tooth harrow

Spring tooth harrow- animal drawn

ACME HARROW

It is a special type of animal drawn harrow having a transverse horizontal frame with stiff curved blades. Also known as blade harrow; curved knife-tooth harrow; pulverizer. The front part of the knife breaks the soil and crushes the clods. This harrow obtains a good pulverization. It is good for creating soil mulch.

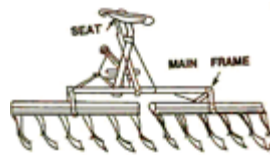

Acme harrow

PATELA

It is a wooden plank used for smoothening the soil and crushing the weeds. It is also used for breaking clods, packing and leveling the ploughed soil and to remove the weeds. It is made of a wooden plank with a number of curved steel hooks bolted to a steel angle section, which is fixed to the rear side of the plank. The cutting edge levels and packs the soil and the curved hooks uproot and collect the weeds. It is a animal drawn version

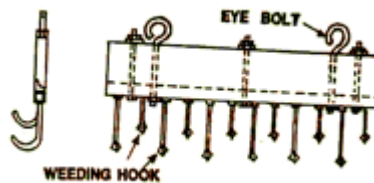

Patela

TRIANGULAR HARROW

It is a spike tooth harrow with triangular frame. The frame is made of wood and pointed spikes are fitted in the frame. The teeth of the spikes are fixed and not adjustable. It is used for breaking the clods and smoothening the soil surface.



Triangular harrow

BLADE HARROW (BAKHAR OR GUNTAKA)

It is an animal drawn implement used to prepare seedbeds in clayey soils and soil mulch for

soil moisture conservation. It consists of one or more blades attached to a beam which works at shallow depth with minimum or nil soil inversion.

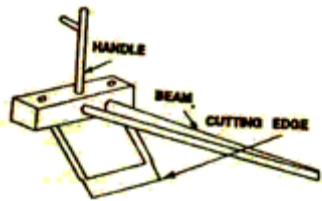

Animal drawn blade harrow



Tractor drawn leveler cum blade harrow

POWER HARROW - TRACTOR DRAWN

A power harrow tills the soil maintaining the same profile of the field. It pulverizes the upper and lower layer of soil without turning them upside down and thus it forms a good seed bed as well as good soil mulch. It consists of two horizontal cross bars fitted with rigid pegs which reciprocate taking power from the PTO of a tractor. The pegs are spaced 200 mm wide and are staggered with respect to each cross bar. The two bars move in opposite directions and hence the implement is dynamically balanced. The oscillating pegs break the clods and pulverizes the soil to a fine tilth. The width of the operation is 2000 mm. and the field capacity is around 1.5 ha/day.



Power harrow - tractor drawn



Power harrow - Power tiller drawn

ROTARY TILLER

The rotary tiller or rotary cultivator is widely considered as the most important implement as it provides fine degree of soil pulverization. It is directly mounted to the tractor and operated. The rotor is The benefits of the rotary tiller are a) effective pulverization of soil ensures good plant growth b) cutting and mixing of stubbles and roots and mixing with soil and c) leveling of the field

The functional components include, rotor fitted with L shaped steel blades (36 - 48 Nos.), gear box, power shaft, sprocket - chain drive, universal joint, leveling board, shield, depth control arrangement, and three point hitching provision. The power from the tractor engine is transmitted to the rotary tiller (rotavator) through PTO (Power Take Off) of the tractor. A

leveling board is attached to the rear side of the unit for leveling the tilled soil. Two numbers of adjustable brackets are provided one each on either side of the unit for controlling the depth of operation. The rotor is operated at 180- 200 rpm

Types of blades used in rotary tillers.

- i. 'L' type blade - Works well in trashy conditions. More effective in cutting weeds and but do not pulverize the soil much.
- ii. Twisted blade - Suitable for deep tillage in relatively clean grounds, but clogging and wrapping of trashes on the tynes and shafts needs frequent cleaning.
- iii. Straight blade - Employed on mulchers designed mainly for secondary tillage.

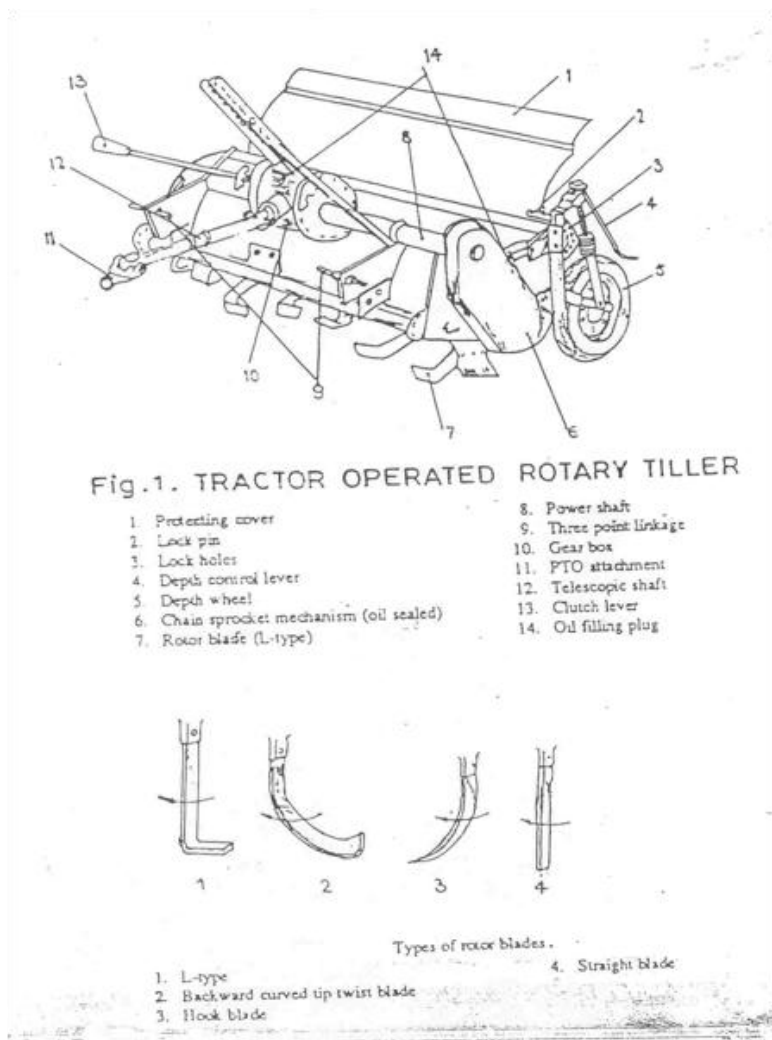

Rotary tiller

LAND ROLLERS OR PULVERISERS

Land rollers or pulverisers are tools used for further preparation of seed bed.

1. CLOD CRUSHER: It is used to finish preparing the seed bed by thoroughly pulverizing and firming the loose soil so that there will not be any large air space or pockets. It presses the upper soil down against the sub soil, making a continuous seedbed in which moisture is conserved and given to the roots of the plants as it is needed.



Single gang land roller (Clod crusher)

2. V- SHAPED ROLLER PULVERIZER: It is constructed of a number of wheel sections arranged on a shaft. The surface of the roller forms a kind of corrugation. so it is also called as corrugated roller. It rolls, pulverizes, packs, levels, cultivates, and mulches the soil.

LEVELERS

Land leveling is a permanent improvement done on agricultural lands. It is carried out to smoothen the contours of land to achieve certain desirable objectives for efficient agricultural production. Land leveling helps for (i) efficient application of irrigation water, (ii) improved surface drainage, (iii) minimizing soil erosion (iv) conservation of rain water in dry lands and The animal drawn leveler consists of a wooden leveling board with a handle . In the front portion of the board two hooks are provided for connecting it to the yoke of the animals.

1. SOIL SCOOP

Soil scoops are used for excavating ditches , clearing drains and doing cut and fill jobs in land leveling . It consists of a trough, a blade , hitching loop and handle. Soil scoops are available Both animal drawn and tractors drawn versions are available

i. Blade: Blade is made of light carbon steel with carbon content varying from 0.5 - 0.6%. The angle of the cutting blade varies from 12° to 15° angle The blade is riveted or bolted to the soil trough.

ii. Soil trough: It is made of mild steel sheet and shaped in to a trough.

iii. Hitching loop: The loop is made of mild steel. The ends of the loop are fitted to the side of the soil trough.. The hitching loop is provided with iron rings or pins for connecting the soil scoop to animals or a tractor

iv. Handle: In animal drawn version there are two handles made of timber or mild steel plate fitted to the loop and used to control the movement of the implement.



Soil scoop - animal drawn



Soil scoop - tractor drawn

2. TRACTOR DRAWN LEVELER

It is a tractor-mounted implement controlled by tractor hydraulics and three-point linkage. It consists of hitch system, replaceable cutting blade with sharp edge, and a curved plate with side wings, which form a bucket.. During operation, the blade digs into the soil and extra soil is collected in the bucket, which is released in the depressions of the field. The angle and pitch of leveler is adjustable. The leveler can also be angled left or right, or reversed for back filling.



Tractor drawn leveler

2. LEVELING BOARD- BULLOCK DRAWN

It is a wooden board of length 2.0m, width 0.4m and thickness 0.3m provided with side wings, hitching braces and handle. The board is hitched to animals and pulled. The blade scrapes soil from elevated places, the soil is moved to places where there are depressions and released. It can be used in leveling of paddy field after puddling.

SECONDARY TILLAGE IMPLEMENTS FOR RICE CULTIVATION

1. CAGE WHEELS

This is an iron wheel, lugged with L angles. The tractor will not work satisfactorily in ploughing / puddling of rice fields due to slippage of rubber wheels. To overcome this difficulty iron wheels are introduced which are called cage wheels.. Cage wheels are of two types viz., half cage wheel and full cage wheel. The iron lugs provide required grip and facilitate easy movement of tractor in rice field. Half cage wheels are fitted to the rubber tyre wheels and used. . For full cage wheels, tyre wheels are removed and used. The width of full cage wheel is 1 m and that of the half cage wheel is 0.5 m.

2. PUDDLER

Puddler is used for churning the soil with standing water while preparing fields for paddy transplanting. It is used after completing an initial ploughing with iron plough or country

plough. It breaks up the clods and churns the soil. The main purpose of puddling is to reduce percolation and leaching losses of water, to kill weeds by decomposition and to facilitate transplantation of paddy seedlings by making the soil softer. Puddling is done in standing water of 5-10 cm depth. Different types of puddlers namely straight blade , helical blade, paddle type, and cage wheel type puddlers are available

Animal drawn puddler consists of four to six number of 0.6m long blades, radial arms to hold the blades, axle, bush bearing, frame, hitching braces, handle etc. While pulling, the blades rotate and puddle the soil. . The weight of the puddler is 30-40 kg.

i. Frame: The frame consists of front, rear and side pieces made of steel or wood.

ii. Puddling unit: Puddling unit consists of blades made of mild steel. The blades are rigidly fixed radial arms

iii. Radial arms: This holds the blades in position. This is made up of mild steel plate.

iv. Axle: The axle is made up of mild steel bar of 25 mm in diameter.

v. Beam: The beam is made up of wood and is suitably placed in the frame with the help of bracer and the other end to the yoke to hitch the animal.

***** 😊 *****



Lecture 08

SOWING METHODS - SEED DRILLS, SEED CUM FERTILIZER DRILLS - COMPONENTS AND FUNCTIONS

Sowing is an art of placing seeds in the soil to have good germination in the field. A perfect sowing gives

1. Correct amount of seed per unit area.
2. Correct depth of sowing
3. Correct spacing between row-to-row and plant to plant.
4. Correct seed rate

SOWING METHODS

(i) Broadcasting (ii) Dibbling (iii) Drilling (iv) Seed dropping behind the plough (v) Transplanting (vi) Hill dropping (vii) Check row planting.

(i) Broadcasting

Broadcasting is the method of random scattering of seeds on the surface of seedbed. It can be done manually or mechanically. When broadcasting is done manually, uniformity of seed placement depends upon the skill of the man scattering the seeds. Soon after broadcasting the seeds are covered by planking or some other devices. Usually higher seed rate is obtained in this system. Mechanical broadcasters are used for large-scale sowing. The device scatters the seeds on the surface of the seedbed at controlled rates.

(ii) Dibbling

Dibbling is the process of placing seeds in holes made in the seedbed and closing the seed with soil. In this method, seeds are placed in holes made at definite depth at fixed spacing. The equipment used for dibbling is called *dibbler*. It is a conical shape instrument used to make proper holes in the field. Small hand dibblers are made with several conical projections made in a frame (Fig.1). This is very time consuming process, so it is not suitable for small seeds. Mostly vegetables are sown in this way.



Dibbler

(iii) Seed dropping behind the plough

It is a very common method of sowing followed by farmers in villages. This method is used for seeds like maize, gram, peas, wheat and barley. A woman/ man walk behind a plough ploughing the land and drop the seeds in the furrows made by the plough. Sowing behind the plough can be done by a device known as *malobansa* . It consists of a bamboo tube provided with a funnel shaped mouth. It is fitted to the handle of the plough. One man drops the seeds through the funnel and other man handles the plough and the bullocks. This method is a slow and laborious method.

(iv) Drilling

Drilling consists of dropping the seeds in furrow lines in a continuous stream and covering them with soil. The spacing between the seeds is not uniform. Seed metering may be done either manually or mechanically. The number of rows planted may be one or more (Figs.2-5). This method is very helpful in achieving proper depth of sowing, proper spacing between seeds and proper seed rate. Drilling can be done by using seed drills of tractor drawn and animal drawn types

(v) Transplanting

Transplanting consists of rising the seedlings in a nursery bed and then planting the seedlings in another field (main field). It is commonly done for paddy, vegetable and flowers. It is a time consuming operation. Equipment used for planting the seedlings in the main field is called *transplanter*.

(vi) Hill dropping

In this method, few seeds are dropped as a hill at a fixed place and not in a continuous stream. The spacing between hill to hill in a row is constant The equipments are called planters

(vii) Check row planting

It is a method of planting, in which row-to-row and plant-to-plant distance is uniform. In this method, seeds are planted precisely along straight parallel furrows. The rows are always in two perpendicular directions. A machine used for check row planting is called check row planter.

SEED DRILL

Seed drill is a machine used for placing the seeds in a continuous stream in furrows at uniform rate and at controlled depth with an arrangement of covering the seeds with soil.

According to the power source used , seed drills may be classified in to (i) Bullock drawn seed drills (ii) Tractor drawn seed drills.. According to the type of seed metering done animal drawn seed drills may be classified into i) manually metered seed drills and ii) mechanically metered seed drill. . In manually metered seed drills a person drops the seeds in the furrows, in mechanically metered seed drills a mechanical device called seed metering mechanism is used to meter the seeds. There are many designs of bullock drawn seed drills and tractor drawn seed drills which are used for sowing..



Seed Drill for Wheat



Gorru



Bullock drawn seed drill



Tractor drawn seed drills



Tractor drawn seed drills

Functions of a seed drill:

Seed drill performs the following functions

1. To carry the seeds.
2. To open furrows at uniform depths
3. To meter the seeds
4. To deposit the seeds in furrows in an acceptable pattern
5. To cover the seeds and compact the soil around the seed.

SEED CUM FERTILIZER DRILL

Seed drills fitted with fertilizer dropping attachments are called seed-cum-fertilizer drills, They deliver both the seeds and fertilizers simultaneously in an acceptable pattern. Seed cum fertilizer drill has a large seed box which is divided lengthwise into two compartments, one for seed and another for fertilizers distribution.

Functions of a seed cum fertilizer drill :

Seed cum fertilizer drill performs the following functions

1. To carry the seeds and fertilizer in separate compartments.
2. To open furrows at uniform depths
3. To meter the seeds and fertilizers
4. To deposit the seed and fertilizer in the furrows in an acceptable pattern
5. To cover the seed and fertilizer and compact the soil around the seed.



Seed-cum-fertilizer drill

COMPONENTS OF A SEED DRILL

A seed drill with mechanical seed metering device mainly consists of:

(i) Frame (ii) Seed box (iii) Seed metering mechanism (iv) drive transmission system v) Furrow openers (vi) Covering device (vii) clutch viii) hitch frame and ix) Transport wheels.

Frame

The frame is usually made of mild steel angle section and flats . It is strong enough to withstand all types of loads in working condition. All other parts of a seed drill are fitted to the frame.

Seed box

It is a box like structure made up of either mild steel or galvanized iron and provided with a lid. In some designs a small agitator is provided at the bottom of the box which agitates the seeds while the drill in operation and prevents clogging of seeds. Seed metering mechanism is placed at the bottom of the box.

Seed metering mechanism

The mechanism which picks up seeds from the seed box and delivers them in to the seed tube is called *seed metering mechanism*. Seed metering mechanism may be of several types: (a) Fluted feed type (b) Internal double run type (c) Cup feed type (d) Cell feed type (e) Brush feed type (f) Auger feed type (g) Picker wheel type and (h) Star wheel type. Usually seed metering mechanism is provided at the bottom of the box.

Drive transmission system

The drive transmission mechanism consists of a wheel, sprocket-chain assembly and a driven shaft that carry the seed picking discs. When the seed drill moves in the field, the drive wheel rotates due to its contact with soil and the sprocket wheel also rotates. The chain connecting the drive wheel sprocket and driven wheel sprocket rotates the shaft carrying the seed metering discs.

Furrow openers

These are the parts which open up furrows in the soil for placing the seeds. Different types of furrow openers in use namely 1. Hoe type 2. Shoe type 3. Stub runner type 4. Full or curved runner type 5. Single disc type 5. Double disc type etc. In cultivator type seed drills the tines work as furrow openers.

Covering device or furrow closer

It is a device which closes the furrow with soil after the seed has been dropped in it. Covering the seeds is usually done by chains, bars, packers, rollers or press wheels, designed in various shapes and sizes.

Transport wheel

There are two wheels fitted on an axle for transporting the drill on roads. Iron wheels are used as transport wheels. Some manufacturers use pneumatic wheels. One of the transport wheels is fitted with a suitable attachment to transmit the motion of the wheel to the seed metering mechanism when the drill is in operation.

TYPES OF SEED METERING MECHANISMS

Some of the seed metering mechanisms used in seed drills are explained here.

(a) Fluted feed type

The fluted wheel also known as fluted roller is driven by a square shaft. There are horizontal grooves provided along the outer periphery of the wheel and wheel can be shifted sideways depending upon the seed rate. These rollers are mounted at the bottom of the seed box. They receive the seeds in the longitudinal grooves and pass on to the seed tube through the seed hole.

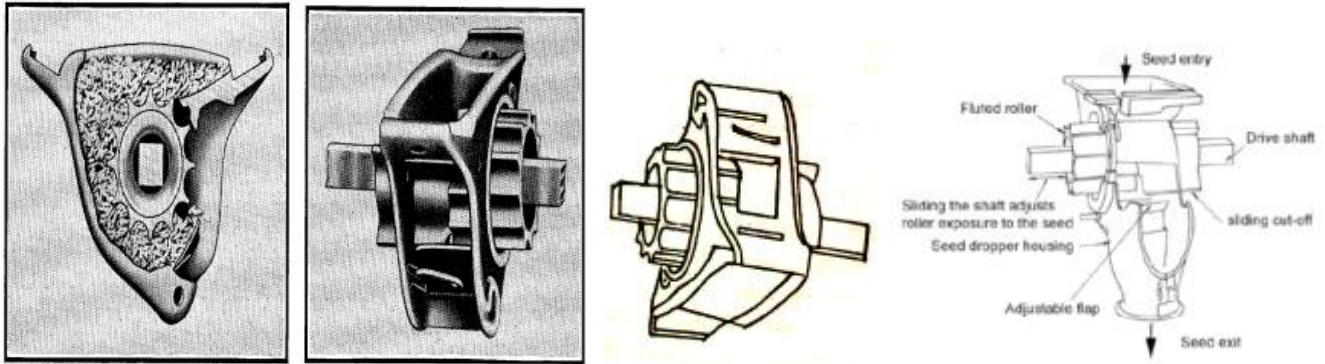

Fig. 11.7. Fluted-wheel type of seed-metering device. (Deere & Co.)

b) Internal double run type

The internal double run feed mechanism has a double face wheel. One face has a larger opening for coarse seeds while other face has smaller openings for small seeds. Flapper gate is provided at the bottom of the box which covers the opening not in use. The rate of seeding is controlled by changing the speed of the internal feed wheels. This is done by meshing appropriate gears.

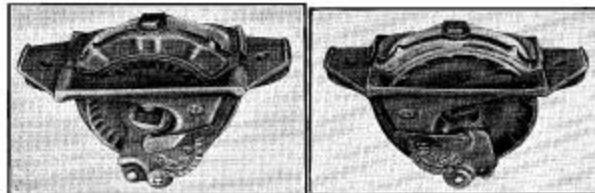

Fig. 11.8. Internal double-run seed-metering device, showing large and small sides of the wheel, for large or small seeds. (Deere & Co.)

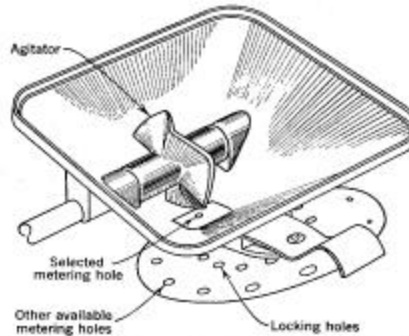

Fig. 11.9. Stationary-opening seed-metering device with agitator, as employed on some vegetable seeders (hopper not shown).

Internal double run

(c) Cup feed mechanism

The mechanism consists of a circular shaft mounted with many circular discs. Each disc is provided with several cups or spoons in a circular path...This arrangement is kept at the bottom of the seed box. When the shaft rotates, the discs also rotates. Seeds are picked up by

the cups and then dropped in to a funnel from where the seeds travel through the seed tube and reach the furrows. The cups have two faces, one for larger seeds and the other for smaller seeds

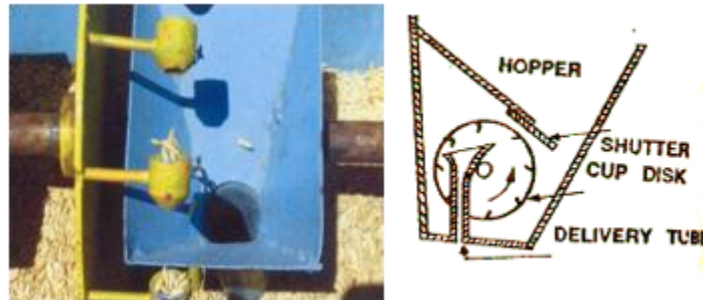

Fig 8. Cup feed mechanism

(d) Cell feed mechanism - It is a mechanism in which seeds are collected and delivered by a series of equally spaced cells engraved on the periphery of a circular plate or wheel.

(e) Brush feed mechanism - It is a mechanism in which a rotating brush regulates the flow of seed from the hopper in to the seed tube. A number of bullock drawn planters in the country use brush feed mechanism.

(g) Picker wheel mechanism - It is a mechanism in which a vertical plate provided with radially projected arms picks up and drop the seeds in to the furrow. It is suitable for large size seeds like potatoes.

(h) Star wheel mechanism - It is a feed mechanism which consists of a toothed wheel, rotating in a horizontal plane and conveying the fertilizer through a feed gate below the Star wheel.

(f) Auger feed mechanism - It consists of an auger which moves the substance from the container and delivers in to the field uniformly. Fertilizer drills are usually provided with auger feed mechanism. Some manufacturers use this mechanism in seed drills also.

TYPES OF FURROW OPENERS

The furrow openers are provided in a seed drill for opening a furrow. The seeds travel through the seed tube and reach the furrow

Different type of furrow openers are: in use (1) Shovel type (2) Shoe type (3) hoe type (4) Disc Type (single disc, double disc).etc

(1) Shovel Type

Shovel type furrow openers are widely used in seed drills. There are three types of shovels in use. They are: (a) reversible shovel (b) single point shovel and (c) spear head shovel.

Shovel type openers are best suited for stony and root infested fields. The shovels are bolted to the shanks at their bottoms. Boots are fitted at the back of the shovels which carry the delivery ends of the seed tubes. In cultivator type seed drills shovel type furrow openers are used.

(2) Shoe Type

It works well in trashy soils where the seed beds are not smoothly prepared. They are made from two flat pieces of steel welded together to form a cutting edge. It is specially suited for black soils. Bullock drawn three tyne seed drills are provided with shoe type furrow openers.

(3) Disc Type

They are two types: (a) Single disc and (b) Double disc types.

Single disc type

Disc type furrow openers are suitable to fields where plant residues or trashes are used as mulches. It consists of a curved disc made of hardened steel. It is set at an angle which while working shifts the soil to one side making a small furrow. Seeds are placed in the furrows. The disc is kept clean by two scrapers, one toe shaped at the convex side and one 'T' shaped at the concave side. It works well in sticky soils also, but the discs are costly and maintenance is bit difficult.

Double disc type

In double disc furrow opener there are two flat discs, set at an angle to each other. The discs open a clean furrow and leave a small ridge in the center. The seeds are dropped between the two discs, providing more accurate placement. It is suitable for trashy lands. Seed drills operated at high speeds; usually use this type of furrow openers.

Seed tube - Seed tubes are provided at the lower end of the feed cups. They conduct seeds from feed cups to the furrow lines through suitable boots and furrow openers. Polypropylene, rubber and steel tubes are used as seed tubes. Minimum diameter of seed and fertilizer tube is 25 mm. **Boot** - It is a part of the sowing equipment which receives the seeds or fertilizers from the seed tube and delivers to the furrow. It is made up of cast iron or mild steel.

TYPES OF FURROW CLOSERS

Drag chain, drag bars, scraper blades, steel press wheels, zero-pressure pneumatic press wheels, disc hillers and various combination of these are used as furrow closers.

PLANTER

Planter is a sowing equipment used for sowing those seeds which are larger in size and cannot be handled by seed drills. Row to row and plant to plant spacing is maintained in a planter.

Potato planter, maize planter, cotton planter are popularly used

Functions of a planter:

- (i) to open the furrow
- (ii) to meter the seed
- (iii) to deposit the seed in the furrow
- (iv) to cover the seed and compact the soil over the seed.

Components of a planter:

A planter consists of:

- (i) hopper
- (ii) feed metering device
- (iii) knock out mechanism
- (iv) cut-off mechanism
- (v) furrow opener
- (vi) furrow closer
- (vii) Drive mechanism (viii) clutch etc..

A planter has separate seed hopper for each row. Hopper is usually made of mild steel or any other suitable material.

Seed metering device in a planter: There are a number of seed metering devices available for use in a planter. The most common device is a rotating circular plate with cells which is provided at the bottom of seed hoppers. In some planters, vertical rotors, inclined rotors, canvas belts are also used. The circular seed plates have notches or holes provided along the periphery called cells which pick up the seeds from seed hopper and drop them in to the seed tube. Depending upon the type of notches provided on the plates, the rotor is further classified in to. (i) Edge drop (ii) Flat drop and (iii) Hill drop rotors. The cells carry the seeds in the cells of the rotor. The flat drop cell carries the seed on a platform of thickness half of the cell depth. Only one seed is allowed in the cell each time. In hill drop rotor, the cells are larger in size and admit many seeds at a time.

The rotating plate receives the seeds from the hopper. The plate moves under an arrangement called cut-off which allows only those seeds which are accommodated in the cells.



Fig. 11.4. Left: Hopper bottom for typical horizontal-plate corn planter. Note the spring-loaded (yielding) cutoff A, and the spring-loaded knockout pawl B. Right: Three types of edge-cell plates used interchangeably in this hopper bottom. (International Harvester Co.)

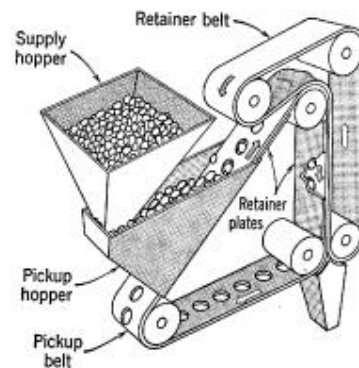
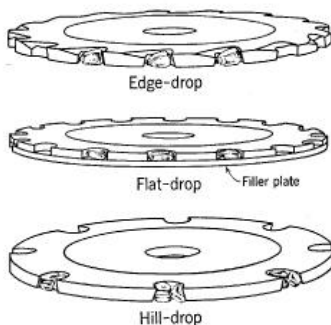

Fig. 11.6. Experimental belt-type planter developed for high-speed drilling of seeds such as peanuts. (J. G. Futral and R. L. Allen. *Agr. Eng.*, April, 1951.)

Cut-off mechanism: It cuts-off or brushes out or removes the excess seeds carried away by the cells thus allowing corrected number of seeds for delivery.

Knock out mechanism: It is a device which knocks out the seeds from the rotor cells . It consists of rollers or star wheels which by pressure releases the seeds from the cells. Seeds fall in to the seed tube and reach the furrow.

Spacing of seeds or hills: The spacing of seeds or hills in the row is determined by the ratio of peripheral speed of the rotor to the forward speed of the planter and the spacing between the cells in the rotor.

The accuracy of the planter depends upon several factors such as: (i) speed of seed plate (ii) shape and size of cells (iii) shape of hopper bottom and (iv) uniformity of seed size.

POTATO PLANTER

Potato is an important crop in India. It requires a lot of labour for sowing in the fields. Potato planter have two types of potato dropping mechanisms namely i.) automatic and ii). Semi-automatic.

POTATO PLANTER (AUTOMATIC SEED DROPPING)

The automatic potato planter consists of a hopper for each row and cups with chain drive mechanism. The graded potatoes are picked up by the cups and carried to furrow opener spout and released in the furrows. A feeder roller connected to the compensating tray which carrying spare potatoes checks up each cup. If a cup is found empty, a potato is released from compensating tray ensuring uniform seed spacing with no missing .The fertiliser and pesticide can also be placed simultaneously. It can plant in 2-4 rows. Capacity is 6000- 14000 potatoes /hr.

POTATO PLANTER (SEMI-AUTOMATIC)

It is used for planting of potatoes. The semi automatic potato planter consists of a hopper , metering disc and furrow openers. The fertilizer application unit can be attached separately. The potatoes from the hopper are placed in the metering disc which contains several compartments. The metering disc is rotated by gear drive mechanism. The ridges are formed by the furrow opener's .The potatoes drop in the furrows due to gravity. It may plant in 2-4 rows. Field capacity is 0.15-0.35 ha/hr.

CALIBRATION OF SEED DRILL

Laboratory testing of a seed drill to determine the rate of seed delivery is called calibration of a seed drill. This is done to ascertain whether a seed drill delivers the seed in accordance with the recommended seed rate or not. If any discrepancy is found between seed delivery of the drill and the recommended seed rate, then the seed metering mechanism is adjusted to deliver correct seed rate. This method avoids the difficulty of setting the seed delivery rate of the seed drill in actual field conditions.

Procedure

- i. Determine the width of sowing of seed drill (W)

$W = M \times S$, metre

Where, M = number of furrow openers

S = Spacing between the furrow openers, meter

- Find the length of the strip of land (L) for an area of $1/25$ ha taking the width of sowing as cover $1/25$ ha

$$L = (1/25) \times 10000 \text{ m}^2 \times 1/w, \text{ meter}$$

$$= 400/W$$

iii. Determine the number of revolutions (N) of the ground wheel of the seed drill required to cover a strip of length L meter

$$L = P \times D \times N = 400/W \text{ metre}$$

$$N = 400 P \times D / W \quad \text{revolutions per minute}$$

iv. Jack the seed drill so that the drive wheel turn freely. Make a mark on the drive wheel and a corresponding mark at a convenient place on the body of the drill to help counting the revolutions of the drive wheel

v. Fill the seed in the seed hopper. Place a container under each boot for collecting the seeds dropped from the hopper

vi. Set the seed rate control adjustment for maximum position and mark this position on the control for reference

- Engage the clutch and rotate the ground wheel for N revolutions

$$(N = 400 \Pi D / W)$$

viii. Weigh the quantity of seed collected in the container and record the observation W_s kg

ix. Calculate the seed rate in kg/ha

Calculation:

Seed collected for an area of $400 \text{ m}^2 = W_s$ kg

$$\text{Seed rate per hectare} = \frac{10000 \times W_s}{400} \text{ kg/ha}$$

x. If the calculated seed rate is higher or lower than the desired rate of selected crop, repeat the process by adjusting the seed rate control adjustment till the desired seed rate is obtained.

SOLVED EXAMPLES

1. Calculate the cost of sowing one hectare of land with a bullock drawn seed drill of size 5×22 cm. The speed of bullocks is 3 km/hr . Hire charge for bullocks is $\text{Rs.}100/-$ per pair/ day,

hire charge for seed drill is Rs.50 / - per day and wages for operator is Rs.100/- per day of 8 hours.

Sol: Width of seed drill = $5 \times 22 = 110 \text{ cm} = 1.1 \text{ m}$

$$\text{Area covered, FCT} = \frac{3 \times 1.1}{10} \text{ ha/hr}$$

$$\text{Time taken to cover one hectare} = 1/\text{FCT} = 1/0.33 = 3.03 \text{ hrs.}$$

$$\text{Cost of sowing / ha} = \frac{100 + 50 + 100}{8} \times 3.03 = \text{Rs.}94.70$$

2 The following results were obtained while calibrating a seed drill. Calculate the seed rate per hectare.

(i) No. of furrows = 10 (ii) Spacing between furrows = 20 cm (iii) Diameter of drive wheel = 1.5 meter (iv) Revolutions of ground wheel rotated for seed delivery = 500 (v) seed collected = 20 kg.

Solution; width of seed drill = $10 \times 20 \text{ cm} = 2 \text{ m}$

Circumference of drive wheel = $\pi \times 1.5 \text{ m}$

Area covered in one revolution = $\pi \times 1.5 \times 2 \text{ m}^2$

Area covered in 500 revolution = $\pi \times 1.5 \times 2 \times 500 = 4712.3 \text{ m}^2$

Seed dropped for 500 revolutions = 20 kg

20×10000

$$\text{Seed delivery rate} = \frac{\text{-----}}{4712.3} = 42.22 \text{ kg / ha.}$$

3. Calculate the time required for sowing 1.6 hectares of land by a five furrow seed drill working at 12.5 cm deep. The speed of seed drill is 3.2 km/hr and pressure exerted by the soil on the seed drill is 0.42 kg/cm². The space between furrow openers is 10 cm and time loss in turning is 10%.

Solution:

width of sowing = $5 \times 10 \text{ cm} = 0.50 \text{ m}$

$$\text{Actual Field capacity FCA} = \frac{3.2 \times 0.5 \times 90}{10 \times 100} = 0.144 \text{ ha/h}$$

Time needed for sowing 1.6 ha = $1.6 / 0.144 = 11.1 \text{ h}$

4. Calculate the seed rate of a 7 x 17 cm seed drill whose main drive wheel diameter is 124 cm and total weight of grain collected in 20 revolutions is 0.423 kg.

Sol. Width of operation = $7 \times 17 = 119 \text{ cm} = 1.19 \text{ m}$
 Circumference of main drive wheel = $\pi \times 1.24 = 3.90 \text{ m}$
 Area covered per revolution = $1.19 \times 3.9 = 4.64 \text{ m}^2$

No. of revolutions/ha = $\frac{10000}{4.64} = 2155.17 \text{ revolutions}$

Seed collected in 20 revolutions = 0.423 kg

Seed rate of the drill = $\frac{2155.17 \times 0.423}{20} = 45.58 \text{ kg/ha}$

MODEL QUESTIONS

1. State the requirements of perfect sowing
2. Compare broadcasting with drill sowing
3. Compare check row planting with transplanting
4. What are the functions of a seed drill?
5. State the advantages of using seed drills.
6. List the types of seed metering mechanisms
7. Mention the components of a seed drill with a neat sketch and explain their importance
8. Differentiate seed drill and seed planter.
9. Mention the different types of furrow openers and their uses.
10. What is calibration of seed drill
11. The following observations are recorded while calibrating the seed drill.
 Number of furrows = 10
 Spacing between the furrows = 20 cm
 Diameter of the ground wheel = 1.5 m
 Speed of rotation of ground wheel = 500
 Weight of seed collected = 20 kg.
 Calculate the seed rate.
12. Seed metering mechanism used in cultivator seed drill is
 - a. Fluted rollers
 - b. Cup feed mechanism
 - c. Brush feed mechanism
 - d. Auger feed mechanism
13. In most of the seed drills drive for seed metering mechanism is taken from
 - a. PTO shaft
 - b. Engine
 - c. Hydraulic system
 - d. Ground wheel
14. A five row 20 cm manual transplanter is pulled at a speed of 1.0 km/h. How much area will be planted in one day of 8 hours if field efficiency is 80 %
 - a. 0.50 ha
 - b. 0.60 ha
 - c. 0.64 ha
 - d. 0.70 ha

15. Knock out mechanism is a device which knocks out the seeds from the cells
Or picker heads of the mechanism. True/False
16. Dropping of seeds in furrow lines in a continuous flow and covering them
with soil is called as
a. Hill dropping b. check row planting c. drilling d. Broadcasting
17. The mechanism used to meter fertilizer in seed cum fertilizer drill is
a. Fluted rollers b. Cup feed mechanism
c. edge drop rotor d. Auger feed mechanism
18. In most of the seed drills drive for seed metering mechanism is taken from
a. PTO shaft b. Engine c. Hydraulic system d. Ground wheel
19. In seed metering mechanisms used in planters the device which knocks out the seeds from
the cells is called
a. Fluted rollers b. Cut-off mechanism
c. Knock-out mechanism d. Drive wheel
20. Knock out mechanism in the seed metering system of a planter brushes
out excess seeds from the rotor true/false
21. Calculate the cost of seeding one hectare of land with bullock drawn seed drill of size 5x22
cm. the speed of bullocks is 3 km/h. Hire charges of bullocks is Rs. 150/ day.. Hire charges of
seed drill is Rs. 100/day. Of 8 hours.
22. A fluted feed seed drill has 8 furrow openers of single disc type. The furrow openers are
spaced 25 cm apart and the main drive wheel has a diameter of 120 cm. How many turns of
main drive wheel would occur when the seed drill has covered 1.0 ha of land.



Lecture 09

PADDY TRANSPLANTERS, TYPES, WORKING PRINCIPLE, FIELD AND NURSERY REQUIREMENTS

Transplanter is equipment used for transplanting mat type paddy seedlings in the main field. It is suitable for all types of paddy varieties grown by transplanting. Both manually operated and mechanically operated transplanters are available. Before transplanting, the field has to be puddled well and allowed for one or two days for consolidation of soil so that the machine can work without sinkage.

MANUAL RICE PLANTER

The machine consists of a seedling tray, six numbers of forks, handle and skids. By pressing the handle, the forks pick-up the seedlings and plant them in 6 rows. For every stroke of the handle the seedling tray moves sideways for uniform picking of seedlings by the forks. The operator has to pull the machine after finishing planting in a row. The row to row spacing is 200 mm. Plant to plant spacing can be set as per space recommendation by pulling the unit manually to the required distance. It can cover 0.25 ha/ day. Two men labour are required one for pulling the unit and another for transporting the mat seedlings. It saves time and money when compared to manual transplanting



Six row manual rice transplanter

SELF PROPELLED PADDY TRANSPLANTER

The self propelled paddy transplanter consists of (i) Air cooled gasoline engine (ii) Main clutch (iii) Running clutch (iv) Planting clutch (v) Seedling table (vi) Float (vii) Star wheel (viii) Accelerator lever (ix) Ground wheel (x) Handle (xi) Four bar linkage mechanism etc. The planter is powered by a 1.2-1,8 HP petrol engine.

Operation

The mat seedlings of age 15-20 days are used for machine planting. Mats are placed on the seedling table. After starting the engine, the running clutch and planting clutch are operated. Four bar linkage mechanism picks up 3 or 4 seedlings in each fork at a time from the mat and

plant them in the puddled soil. A fiber glass float supports the machine on the soil while working in the field. Two ground wheels driven by the gear box moves the unit. There is a marker which demarcates the transplanting width while in operation. The machine maintains a row to row spacing of 28 cm to 30 cm and plant to plant spacing of 14 to 16 cm. The planting capacity of the machine is about 0.05 to 0.1 hectare per hour Power requirement is about 1.2 to 1.8 HP petrol engine. It saves time and money when compared to manual transplanting.

Drive for four bar mechanism

Power from the engine goes to the main clutch from where it is divided into two routes, one goes to planting clutch and the other goes to running clutch. Unless the planting clutch is operated , the four bar linkage mechanism does not work.



Self propelled rice transplanter



Self Propelled Rice Transplanter in Operation

MODIFIED MAT NURSERY FOR MACHINE PLANTING

A modified mat nursery establishes seedlings in a layer of soil mix, arranged on a firm surface. Seedlings are ready for planting within 15-20 days after seeding (DAS). The modified mat nursery uses less land, can be installed closer to the house than traditional field nurseries, and uses less labor for both transporting seedling mats and replanting. As a result, root damage is minimal while separating seedlings.

Establishing a Modified Mat Nursery

- 1. Seed:** To plant 1 ha (with 2 seedlings/hill at 20 X 20 cm spacing), use 18-25 kg good quality seeds (i.e., >80% germination and establishment).: Good seeds result in lower seed rate, more uniform germination, vigorous seedlings, less replanting, fewer weeds, and 5-20% higher yields.
- 2. Nursery area:** Prepare 100 m² nursery for each 1 ha to be planted. Select a level area near the house and/or a water source. If area is not sufficiently compacted, then spread a plastic sheet or banana leaves on the marked area to prevent roots growing into soil.
- 3. Soil mixture:** Four (4) m³ of soil mix is needed for each 100 m² of nursery. Mix 70- 80% soil + 15-20% well-decomposed organic manure + 5-10% rice hull or rice hull ash. Incorporate around 20 kg N/ha (1.5 kg powdered di-ammonium phosphate or 2.0 kg 15-15-15 powdered NPK fertilizer for every 100 m² of nursery area).
- 4. Pre-germinating seed:** Soak the seeds for 24 h (some varieties may need longer to bud). Drain and incubate (cover and keep moist) the soaked seeds for 24 h. In this time, the seeds sprout (bud) and the first seed root grows to 2-3 mm long.
- 5. Laying the soil mixture:** Place a wooden frame of 0.5 m long, 1 m wide and 4-cm deep divided into 4 equal segments on the plastic sheet or banana leaves. Fill the frame almost to the top with the soil mixture. Cover the seed with soil mix and wet.
- 6. Sowing:** Sow the pre-germinated seeds uniformly and cover them with a thin layer of dry soil. (Approximately 1 seed/cm²)
- 7. Soaking the seedbed:** (a) Sprinkle water immediately to soak the bed. (b) Remove the wooden frame and continue the process (i.e., fill soil mix-sow seed-cover seed-water) until the required nursery area is completed.
- 8. Watering:** Water the nursery as needed to keep the soil moist. Protect the nursery from heavy rains for the first 5 days. If the nursery can be flooded then at 7 DAS, maintain a 1-cm water level around the mats. Drain the water 2 days before removing the seedling mats for transplanting
- 9. Fertilizer topdressing (optional):** If temperature and water are adequate, but the seedlings show yellowing (N deficiency). Sprinkle seedlings with 0.5% urea (1.5 kg Urea in 300 l water/100 m²).m
- 10. Lifting seedling mats:** Seedlings reach sufficient height for planting in 15-20 DAS. Lift the seedling mats and transport them to main field.



FIELD PREPARATION FOR RICE TRANSPLANTING

Plough the field 20-25 cm deep using a mould board plough or wooden plough to expose the eggs of harmful insects, pests and rhizomes of weeds. Keep the field flooded or saturated with water. After two or three days, puddle the soil using a puddler three or four times with standing water and complete a week ahead of transplanting. Puddling helps to kill the weeds and buries them in puddle layer. The rate of germination of weeds is also reduced in subsequent growing period of crop. Puddling helps to create beneficial physical, biological and chemical conditions for the growth of rice plants. Soil surface is left in a more even condition. Apply uniformly half of nitrogen and total quantities of phosphorus and potash on drained surface at the time of last puddling and incorporate in the top 10-15 cm deep soil.



Lecture 10

IMPLEMENTS FOR INTERCULTURAL OPERATIONS - HOES, LONG HANDLED WEEDERS, CULTIVATORS, AND ROTARY TILLERS

The operations performed in the field after sowing but before harvesting the crop are called as intercultural operations. Interculturing is described as breaking the upper surface of soil, uprooting the weeds (unwanted plants), aerating the soil, thereby promoting the activities of microorganism and making good mulch, so that moisture inside the field is properly retained from evaporation.. These operations are accomplished by means of many tools and equipments, such as hoes, cultivators, harrows, rotary hoes etc.

HAND HOE

Hand hoe is the most popular manually operated weeding tool use in the farm. It consists of an iron blade and a wooden handle. The operator holds the handle and cuts the soil with the blade to a shallow depth of 2-3 cm thereby weeds are cut and soil is stirred. The handle is short (30-40cm long) hence the operator uses the tool in bending posture. The coverage is 5-7 cents per day.



Hand hoe

HOE COME RAKE

The hoe cum rake is multipurpose hand tool, which consists of a flat blade on one side like powrah and prongs on the other side. The blade and prongs are either made from single stock with an eye in the centre or joined to an eye by welding. A wooden handle is fitted to the eye for operation. The flat blade is used for digging and rake side for weeding and collection of weeds and trashes. The hoe cum rake is a secondary nursery bed preparation tool and is used for lighter operations. The flat end of the tool is operated with impact action and rake end by

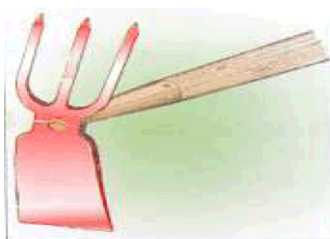

LONG HANDLE WEEDERS

Hand hoes exert greater strain on the operator because of the short handle with necessitates the operator to do weeding job in bent posture. To avoid this nowadays long handles are used in hoes and hence they are called as long handle weeders. The popular long handle weeders available are a) star type weeder b) peg type weeder. These weeders are also called as dry land weeders since they are used in dry lands

a) Star type weeder : It is suitable for weeding in dry lands. It can be used in garden lands also when the soil moisture is low (10-15 %). One limitation is that it works well in line sown crops and not in broadcasted fields. It consists of a blade for cutting the weeds, a fulcrum wheel for push-pull movement and a long handle for easy operation. Long handle reduces strain on the operator. The radial arms of the fulcrum wheel is cut in to star like projections and hence the name star type weeder. Star wheel is designed for loamy soils. The operating width of the blade is 120 mm. The coverage is 0.05 ha/day.

b) Peg type weeder: It is suitable for weeding in dry lands. It can be used in garden lands also when the soil moisture is low (10-15 %). One limitation is that it works well in line sown crops and not in broadcasted fields. It consists of a blade for cutting the weeds, a fulcrum wheel for push-pull movement and a long handle for easy operation. Long handle reduces strain on the operator. There are pegs welded on the periphery of the wheel hence the name peg type weeder. Peg type wheel is designed for clayey soils. The operating width of the blade is 120 mm. The coverage is 0.05 ha/day.

Both star type and peg type weeders are also called as dry land weeders.

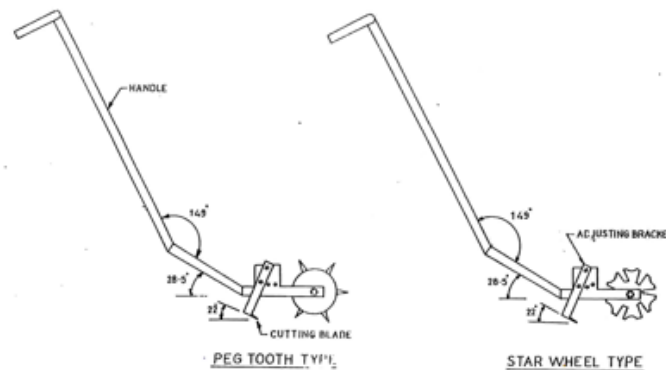

Fig.1. IMPROVED DRYLAND WEEDER

c) Wheel hoe

The wheel hoe is a widely accepted weeding tool for weeding and intercultural in row crops. It is a long handled tool operated by pushes and pull action. The general construction of wheel hoe comprises of a wheel, tool frame, a set of replaceable tools and a handle. Different types of soil working tools such as straight blade, V-blade, sweep, shovel, etc. can be used for different works namely weeding, soil mulching, stirring etc. Long handle reduces drudgery to operator. Wheel reduces energy requirement for pushing. All the soil working components of the tool are made from medium carbon steel. The coverage is 0.05 ha/day.



Cono weeder



Cono weeder in operation

CULTIVATORS

It is an implement for inter cultivation with laterally adjustable tines or discs to work between crop rows. This can be used for seed bed preparation and for sowing with seeding attachment. The times may have provision for vertical adjustments also.

The cultivator can be 1) Disc cultivator, 2) Rotary cultivator, 3) Tine cultivator.

Disc cultivator

It is a cultivator fitted with discs.

Rotary cultivator

It is a cultivator with tines or blades mounted on a power driven horizontal shaft.

Tine cultivator

It is a cultivator fitted with tines having shovels.

The cultivator stirs the soil, and breaks the clods. The tines fitted on the frame of the cultivator comb the soil deeply in the field. A cultivator performs functions intermediate between those of plough and the harrow. Destruction of weeds is the primary function of a cultivator. The following are a few important functions performed by a cultivator.

1. Destroy the weeds in the field.
2. Aerate the soil for proper growth of crops.
3. Conserve moisture by preparing mulch on the surface.
4. To sow seeds when it is provided with sowing attachments.
5. To prevent surface evaporation and encourage rapid infiltration of rain water into the soil.

Depending upon the type of power available for the implement, the cultivator can be classified as 1) Tractor drawn, 2) Animal drawn.

Tractor Drawn Cultivator

It may be 1) Trailed type 2) Mounted type.

Trailed type cultivator

It consists of a main frame which carries a number of cross members to which tines are fitted. At the forward end of the cultivator, there is a hitch arrangement for hitching purpose. A pair of wheels are provided in the cultivator. The life is operated by both wheels simultaneously so that draft remains even and uniform. The height of the hitch is adjusted so that main frame remains horizontal over a range of depth setting. The tines in each row are spaced widely to allow free passage of the soil and trash around them. The tines in subsequent rows are staggered so that the implement can cover the entire width nicely. The depth of working is set roughly by adjusting the tine in their clamps and the final depth control is done by a screw lever. Usually the tynes are damaged due to turning the implement at the headland without lifting it up. Care should be taken to lift the tines off the ground before turning.

Mounted Cultivator

Tractors fitted with hydraulic lift operate the mounted type cultivators. A rectangular frame of angle iron is mounted on three point hydraulic linkage of the tractor. The cross members carry the tines in two staggered lines. For actual cutting the soil, different types of shovels and sweeps are used. a few important shovels and sweeps are a) Single point shovel b) Double point shovel c) Spear head shovel d) Sweep e) Half sweep f)Furrower.

Depending upon the type of soil and crop, shovels are chosen for use on the cultivators. Usually tractor drawn cultivators are of two types, depending upon the flexibility and rigidity of tines (i) Cultivator with spring loaded tines (ii) Cultivator with rigid tynes.

CULTIVATOR WITH SPRING LOADED TINES

A tine hinged to the frame and loaded with a spring so that it swings back when an obstacle is encountered, is called spring loaded line. Each of the tine of this type of cultivator is provided with two heavy coil springs, pre- tensioned to ensure minimum movement except when an obstacle is encountered. The springs operate, when the points strike at roots or large stones by allowing the tines to ride over the obstruction, thus preventing damage. On passing over the obstruction, the tines are automatically reset and work continues without interruption. The tines are made of high carbon steel and are held in proper alignment on the main frame members. This type of cultivator is particularly recommended for soils which are embedded with stones or stumps. A pair of gauge wheel is provided on the cultivator for controlling the depth of operation. The cultivator may be fitted with 7, 9, 11, 13 tines or more depending upon the requirements.

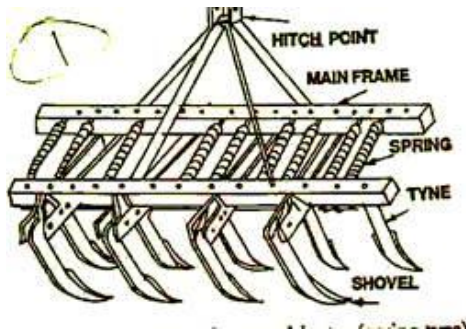

Tractor drawn cultivator- spring loaded tines



Tractor drawn cultivator- spring loaded tines

CULTIVATOR WITH RIGID TINES

Rigid tines of the cultivators are those tines which do not deflect during the work in the field. The tynes are bolted between angle braces, fastened to the main bars by sturdy clamps and bolts. No springs are available with these cultivators. Spacing of the tines is changed simply by slackening the bolts and sliding the braces to the desired position. Since rigid tines are mounted on the front and rear tool bars, the spacing between the tynes can be easily adjusted without getting the tines choked with stubbles of the previous crop or weed growth. A pair of gauge wheel is used for controlling the depth of operation.



Rigid tyne cultivator

TYPES OF SHOVELS AND SWEEPS USED IN TINE CULTIVATORS.

Shovel type blades

- Duplex shovel or spear head shovel – for sleeve type tines

- Single point shovel – spring tooth
- Double point or reversible shovel – for spring tooth

Sweeps blades

- Full sweep
- Half sweep right
- Half sweep left
- High speed sweeps

Type of soil, crops and weeds influence the use of a shovel or a sweep. Shovels and sweeps should be operated as shallow as possible to prevent pruning of roots from the plants thereby injuring the crop. Sweeps should be set almost flat. When the point is resting on the floor, or ground., the outer tip of the wing should be elevated only 3-6 mm above the floor. The shovels and sweeps should be set in between the crop rows 5 cm away and at equal distances on each side of the row to avoid any damage to the standing crop.

Setting of blades in a cultivator

When the cultivator has two rows of blades, then the blades are arranged in a staggered way between the two rows

ANIMAL DRAWN CULTIVATOR

a) Sweep

It is an intercultural implement used for removing shallow rooted weeds in between crop rows. It consists of V shaped blades with bevel edged wings called sweeps. The blades are fitted to the tines by means of counter sunk bolts and nuts and the tines are fitted to a frame. By skimming action under the soil at a shallow depth of 2 to 3 cm, the sweep blades cuts the weeds. By the cutting action the blades break the capillary passages in the soil and provide soil mulch for moisture conservation. The coverage is 1.75 to 2.5 ha/ day. The salient features of the unit are:

- Suitable for all row crops and soils; provides soil mulch and conserves soil moisture

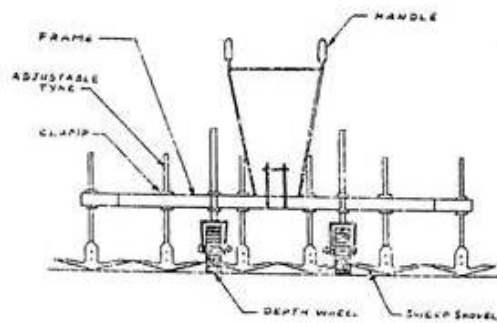

Animal drawn sweep

b) Junior hoe

It is intercultural equipment used for weeding between the rows of standing crops. It consists of six numbers of curved tines fitted with reversible shovels and attached to a framework with hitching arrangement. The tines are arranged in three rows in staggered way, A handle and beam are fixed to the framework for guiding and attaching the unit to the yoke of the animals. The spacing between the shovels can be adjusted according to the row spacing of the crop. The curved nature of tines gives spring action when struck against stones or roots and releases the tines from the obstacle. The coverage is 1.5 ha per day.

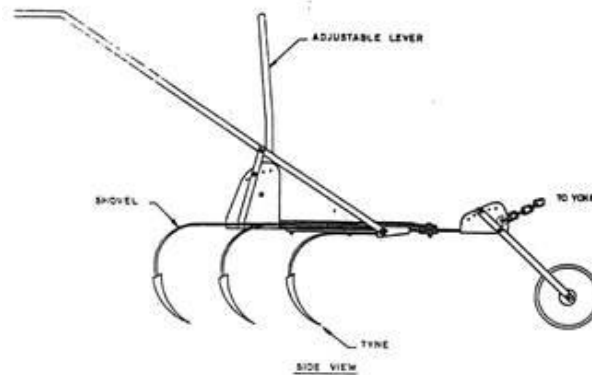

Junior hoe

c) Duck foot cultivator

It is a type rigid cultivator which is used mostly for shallow ploughing, destruction of weeds and retention of moisture. It consists of steel frame and rigid tines to which sweeps are attached. The implement is attached to the tractor with three point hitch system and is controlled by hydraulic system. The sweeps are fabricated from high carbon steel. Number of sweeps can be reduced according to requirement. Usually this cultivator is about 225 cm long; 60 cm wide with 7 sweeps.

ENGINE OPERATED WEEDER

It is used for both intercultural and secondary tillage operations namely stirring the soil, uprooting the weeds, breaking clods, covering seeds etc It consists of a 3-hp engine (petrol start kerosene run), a pair of ground wheels, a cultivator frame with sweep or shovel blades, steering clutch, main clutch, handle, a tail wheel and other control levers. The engine power is transmitted to ground wheels through belt-pulley and sprocket - chain mechanisms. Ground wheels act as traction wheels and pull the cultivator when moving; The tines to be set between rows with sufficient space away from plant stems. To avoid any damage to plants. The tail wheel is provided at the rear of the cultivator frame by raising or lowering of which the operating depth of the blades can be altered. The field capacity is 0.75 - 1.0 ha per day. The salient features of the unit are:

- Useful for weeding in row crops like tapioca, cotton, sugarcane, maize, tomato and pulses whose rows spacing is more than 60 cm
- Can be used for weeding in orchards, coconut and areca nut fields.

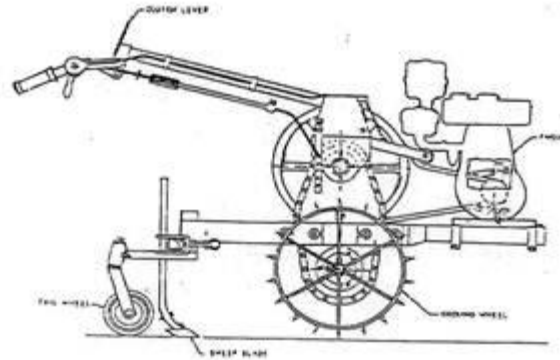

Fig.3. ENGINE OPERATED WEEDER

ENGINE OPERATED ROTARY TILLER

It is a walking type tiller used for plains and hilly regions. It is used for both intercultural and secondary tillage operations namely stirring the soil, uprooting the weeds, breaking clods, covering seeds etc It consists of a 3-hp engine (petrol start kerosene run), a rotor with L blades, rotor drive mechanism, handle and other control levers. When engine power is transmitted to rotor, the rotor rotates and till the soil. The rotor rotates in the forward direction and hence there is a forward push facilitating the forward movement of the tiller. The field capacity is 0.75 - 1.0 ha per day. The salient features of the unit are:

- Useful for weeding in row crops like tapioca, cotton, sugarcane, maize, tomato and pulses whose rows spacing is more than 60 cm
- Can be used for weeding in orchards, coconut and arecanut fields.
- Suitable for hilly regions also
- Depth of cut is 8-12 cm



Engine operated rotary tiller



Tractor operated rotary tiller

Model questions

1. Define inter cultivation in agriculture. Mention some tools and implement used in inter cultivation
 2. Explain about blade harrow
 3. Explain about junior hoe
 4. Explain about engine operated weeder
 5. Mention the conditions where in you will use junior hoe
 6. Name two implements used for conserving soil moisture in dry lands
 7. List the types of weeders
 8. Mention a neat sketch and explain the components of cono weeder their
 9. Differentiate star and peg type weeders.
 10. state the advantages of long handled weeder
- A11. Junior hoe is primarily used for
- | | |
|-------------------|-------------------------|
| a. breaking clods | b. seed bed preparation |
| c. weeding | d. none |
- A 12. The main advantage of using long handle weeders is
- | | |
|------------------------------|--------------------------|
| a. Less drudgery to operator | b. Less area of coverage |
| d. Cheaper cost of weeder | d. Traditional tool |



Lecture 11

SPRAYERS AND THEIR FUNCTIONS, CLASSIFICATION, MANUALLY OPERATED SPRAYERS, POWER SPRAYERS - DUSTERS, TYPES AND USES SPRAYERS

Sprayer is a machine used to apply liquid chemicals on plants to control pest and diseases. It can also be used to apply herbicides to control weeds and to spray micro-nutrients to enhance plant growth

The main functions of a sprayer are

- Breaking the chemical solution in to fine droplets of effective size.
- Distributing the droplets uniformly over the plants.
- Applying the chemicals with sufficient pressure for positive reaching the plants
- Regulating the amount of liquid applied on plants to avoid excessive application.

Desirable quality of a sprayer

A good sprayer should possess the following qualities

- It should produce a steady stream of spray material in desired droplet size so that the plants to be treated may be covered uniformly.
- It should deliver the liquid at sufficient pressure so that the spray solution reaches all the foliage and spreads uniformly over the plant body.
- It should be light in weight yet sufficiently strong, easily workable and repairable.

DIFFERENT SPRAYERS AT A GLANCE



Hand-held-sprayers



Nozzle and pump of hand-



Backpack sprayer

held sprayer



Knapsack Hand Sprayer



Stainless Steel and Brass knapsack sprayers



Brass tank knapsack sprayers



Stirrup sprayer



Rocker sprayer



Hand compression spray



Pedal operated pump



knapsack power sprayer



Knapsack Power Sprayer cum duster



High power pump for sprayers



Trailer Sprayer (with Snyder Super poly Tank)



300 gallon 3pt. mounted sprayers



Tractor mounted field sprayers



Trailer type Orchard sprayers

BASIC COMPONENTS OF A SPRAYER

Components of a sprayer are as follows

1. Pump b) Chemical tank c) agitator d) Air chamber e) pressure gauge f) Pressure regulator g) valves h) Strainer i) suction line j) delivery line k) nozzles

Pump: A pump is a device used to move fluids, such as liquids or slurries, or gases from one place to another. A pump displaces a volume by physical or mechanical action. Most hydraulic sprayers are equipped with positive displacement pumps capable of developing pressure, required for many spraying jobs. The discharge capacity of these pumps is approximately proportional to the speed. A pressure relief valve or by-pass valve is required to protect these positive acting pumps from damage when the discharge line is closed and for the convenience of the operator.

Tank: It is the container to hold the chemical solution. It is made up of PVC, Brass, etc. It is usually made of metal sheet or synthetic rubber or plastic having good resistant quality against corrosion, erosion, and similar actions. The size of the tank varies according to the pump capacity and the requirements.

Agitator: It is the device which stirs the solution and keep the contents in homogenous condition. Positive agitation of spray material in the tank is essential to permit using the full range of spray materials including powdery emulsions, fungicides, cold water paints or other spray material. The propeller or paddle type mechanical agitators or hydraulic agitators are very common.

Air chamber: In a reciprocating type pump, an air chamber is provided on the discharge line of the pump to level out the pulsations of the pump and thus providing a constant nozzle pressure

Pressure gauge: It is a dial gauge which indicates the pressure at which the liquid is delivered from the pump. A pressure gauge properly calibrated, within the pressure range of the pump is provided on the discharge line to guide the operator for making proper adjustment of the pressure at site.

Pressure regulator: The pressure regulator serves several important functions. It is the means of adjusting the pressure as required for any spray job within the pressure range of the pump. With the positive displacement type of pump, it also serves as a safety device in automatically unloading the excess pressure by directing the unused discharge flow from pump back to the tank.

Valves: A valve is a device that regulates the flow of a fluid (gases, liquids, fluidized solids, or slurries) by opening, closing, or partially obstructing various passageways.

Cut-off valve is provided in the delivery line to control the flow from the pump,

By-pass valve is provided in the delivery line to by-pass the flow from pump to tank when flow in delivery line is reduced than the pump capacity

Relief valve - It is an automatic device to control the pressure of fluid or gas within a range a predetermined pressure.

Strainer: It is a small circular plastic ring with nylon wire mesh to filter any dust particle coming with the chemical solution It is included in the suction line between the chemical tank and the check valves. In some sprayers strainers are provided at the mouth of the chemical tank. eg. Knapsack sprayers

Nozzles: It is the component which breaks the fluid in to fine droplet. Atomization of spray fluid is usually achieved by discharging the liquid through an orifice called nozzle under pressure. Atomization is also achieved by breaking up the jet of liquid with a blast of air.

Spray gun - It is a hand held metallic or PVC pipe to one end of which the nozzle is fitted and a flow cut off valve and a handle are fitted at the other end. The delivery hose is connected to the spray gun. It conducts the fluid from the delivery hose to the nozzle. The operator holds the gun and does the spraying job. Area of coverage by a spray gun is less compared to the coverage of a spray boom. Spray guns are used with low power sprayers E.g. Knapsack sprayers, rocker sprayer.

Spray boom - It is a long metallic or PVC pipe to which several nozzles are fitted with. The delivery hose is connected to the spray gun. High power and high capacity sprayers use spray booms. The coverage is larger compared to spray guns. Booms are usually mounted on suitable structures and used. E.g. Tractor operated sprayers, power tiller operated sprayers.

Over-flow pipe - It is a conduit pipe through which excess fluid from a pump is by-passed in to chemical tank by the action of a relief valve or pressure regulator.

COMPONENTS A OF NOZZLE

Nozzle body - It is the main component which encloses all other components of a nozzle.

Swirls plate - It is metal disc with two tangential holes which imparts a swirl or rotation to the liquid passing through it.

Nozzle disc - It is the component which breaks the fluid in to fine droplet. It is a flat disc with an orifice at the centre. When the spray solution reaches the disc from the swirl plate the disc builds up further pressure on the fluid and when the fluid passes out of the orifice, it breaks in to fine droplets. The disc has a specific design to impart a hollow cone or solid cone or a flat fan type of discharge to the outgoing fluid.

The popular nozzles are a) hollow cone b) solid cone c) fan or flat type

Strainer- It is a small circular plastic ring with nylon wire mesh to filter any dust particle coming with the chemical solution

Spacer: There are two number of runner/ plastic rings placed in between nozzle plate and swirl plate and between swirl plate and strainer for effective travel of the solution

TYPES OF SPRAYERS

Based up on the volume of liquid handled ,sprayers may be classified in to

1. High volume sprayer (more than 400 litres /ha)
2. Low volume sprayer (5 to 400 litres/ hectare)
3. Ultra low volume sprayer (ULV) spray (less than 5 litres /ha).

The selection technique depends up on type of vegetation, kind of pests and approach to the field.

ULTRA LOW VOLUME SPRAYER

ULV Sprayer is used to spray chemicals on row crops like cotton, cowpea, groundnuts , tobacco and vegetables. It is ideally suited for home gardens. It is a hand-held sprayer with a spinning / rotating disc designed for ultra-low volume (ULV) and controlled droplet application of insecticides, fungicides, pesticides, herbicides and all liquids. Rotating disc technology ensures efficient liquid atomization to give appropriate droplet size. ULV formulations are applied at only 2.5-7.5 litres / ha. One hectare of crop can be treated in around 2.5 hour

HAND ATOMIZER

This sprayer is also ideally suited for home gardens and small fields. It consists of a container of 0.5 to 3.5lit capacity a built in air pump, pressure gauge , nozzle and flow cut off lever. The tank is to be filled with $\frac{3}{4}$ th volume. The pump is operated to build pressure in the tank of 0.15-0.3 kg/cm² . When the flow cut off lever is pressed , the fluid passes through the nozzle and spraying is done. The application rate ranges from 45 to 100 litres /ha.

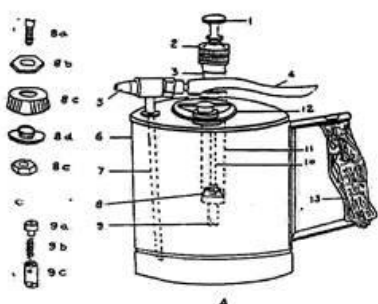

Fig. 1. Pneumatic hand sprayers for kitchen-garden.
 A. 1. Knob 2. Cap 3. Air pump 4. Cut-off lever
 5. Nozzle 6. Tank 7. Discharge tube 8. Bucket
 assembly. 8a. Lower end of plunger rod 8b. Upper
 plate 8c. Leather cup 8d. Lower plate 8e. Nut
 9. Air-check valve assembly. 9a. Air-check valve
 9b. Spring 9c. Valve cap 10. Plunger rod 11. Pump
 barrel 12. Filler hole 13. Handle.



Hand atomizer

HAND COMPRESSION SPRAYER

It is suitable for applying chemicals for field crops and lawns. Similar to hand atomizer this sprayer also consists of a tank of 10-12 lit capacity for holding spray material, a vertical air pump, pressure gauge, filling port, spray lance, nozzle and a flow control lever. The chemical tank is filled 75-80 % volume. The pump is operated to pump air in to the tank to build pressure up to 2.0 - 3.5 kg/cm². When the flow cut off lever is pressed, the fluid passes through the nozzle and spraying is done. The sprayer is carried on the shoulder of the operator. The application rate ranges from 45 to 100 litres /ha.

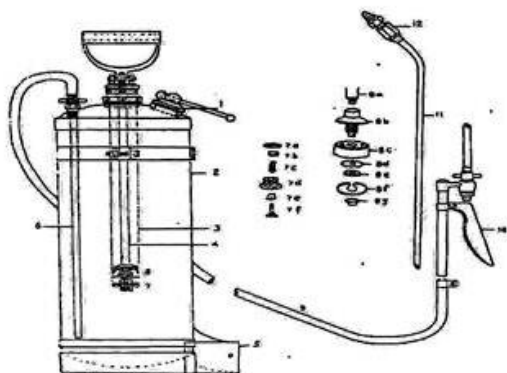
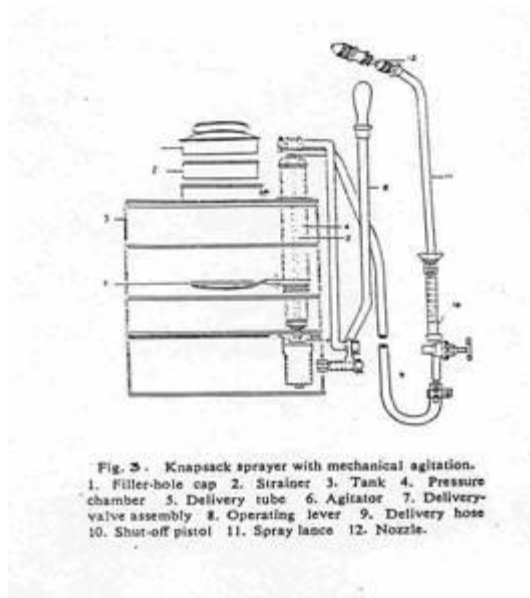

Fig. 2. Hand compression sprayer.
 1. Filler-hole cap 2. Tank 3. Pump barrel 4. Plunger rod
 5. Back rest 6. Discharge tube 7. Air-check valve assembly,
 7a. Gasket 7b. Spring retainer 7c. Spring 7d. Valve housing,
 7e. Valve seat 7f. Air-check valve 8. Plunger bucket
 assembly 8a. Lower end of plunger (upper plate) 8b. Cutter
 pin 8c. Bucket 8d. Lower plate 8e. Locking out 8f. Bucket
 spreader spring 8g. Retainer cap for spring 9. Delivery hose
 10. Trigger shut-off cock 11. Spray lance 12. Nozzle.



Hand compression sprayer

KNAPSACK SPRAYER (HAND OPERATED)



This sprayer is suitable for applying chemicals to several field crops. The operator carries the sprayer on his back and hence the name knapsack sprayer. It has a flat or bean-shaped tank of 10-15 litres capacity., a hydraulic pump fitted inside the tank, a handle to operate the pump, agitator, filter, delivery hose, and spray gun with nozzle and flow control lever. The tank is made of either brass or PVC material. The tank is filled with chemical solution. When the pump is operated, it draws the fluid through the suction hole and delivers it to the spray gun, When the cut off lever is pressed spraying is done through the nozzle as fine droplets. The pressure developed in these sprayers depends on the pump and varies from 3 to 12 kg/cm² The application rate is 500 lit/ha. The coverage is 0.5-1.0 ha/day.

Salient features of knapsack sprayers.

1. Useful to develop high pressure with less effort.
2. Light in weight and easy to carry on the back of the operator..
3. High work rate and economical.
4. Robust and simple to maintain.
5. Both left and right hand operation
6. 10-15 lit. capacity
7. Easy to spray chemicals.

ROCKER SPRAYER

Rocker sprayer is mainly used for spraying fruit trees in orchards, coconut and areca nut trees, flower gardens, and cotton and tapioca fields. It consists of a piston type pump, a platform with fork, a lever to operate the pump, pressure chamber, suction hose with strainer, delivery hose, and a spray gun with flow control knob and nozzle. The pump builds up a pressure up to 14-18 kg/cm² which facilitates the use of the sprayer for tree spraying. The Pressure chamber helps for continuous spraying. The chemical is taken in a separate container

and the suction hose is kept in the chemical container. When the pump is operated, it draws the fluid through the suction hose and delivers it to the delivery hose through the pressure chamber. When the flow control knob is turned, the fluid is sprayed through the nozzle. The output of the sprayer is 70-90 lit/hr with one nozzle. Coverage is about 1.5 ha/ day.

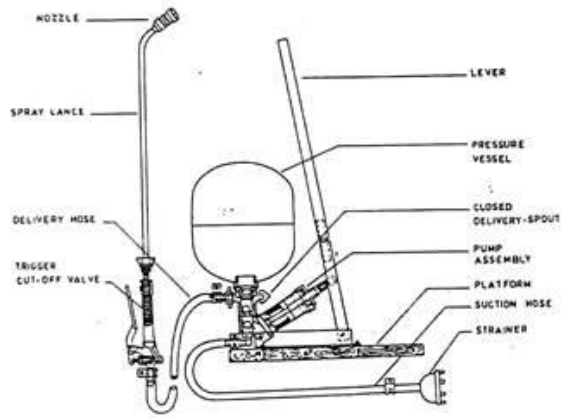

Rocker sprayer



Rocker sprayer

FOOT OR PEDAL OPERATED SPRAYER

The foot or pedal sprayers, as they are commonly called, consist of a plunger assembly, stand, suction hose, delivery hose, spray gun with a nozzle etc. One end of the suction hose is fitted with a strainer and the other end is connected to the pump inlet opening. Similarly, the delivery hose is fitted at one end to the delivery opening of the pump and the other end to the spray gun. Constant pedaling is required for continuous spray. It develops a pressure of 17-21 kg/cm². The chemical is taken in a separate container and the suction hose is kept in the chemical container. When the pump is operated by the foot, it draws the fluid through the suction hose and delivers it to the delivery hose. When the flow control lever is pressed, the fluid is sprayed through the nozzle. Agitation of chemical solution is done by supplying a portion of air from the blower, The discharge rate with one nozzle is 110-135 l/hr and coverage is 1.0 ha/ day

KNAPSACK MOTORIZED MIST BLOWER CUM DUSTER

It is the simplest engine driven sprayer used in agriculture. It is carried on the back of the operator. It is used for spraying to all types of field crops most popularly to paddy, groundnut, cotton and vegetable crops. It consists of a 1.2- 3.0 hp high speed petrol engine, a blower, a 12 lit chemical tank, delivery hose, fleeted air hose, flow regulator knob and a plastic atomizer grate. The tank is filled with the required chemical solution. When the engine is started, the blower generates a high velocity air to which the chemical solution is fed. The chemical mixed air stream is broken in to fine droplets at the atomizer grate and sprayed. . By changing few parts the sprayer can be converted in to a duster.

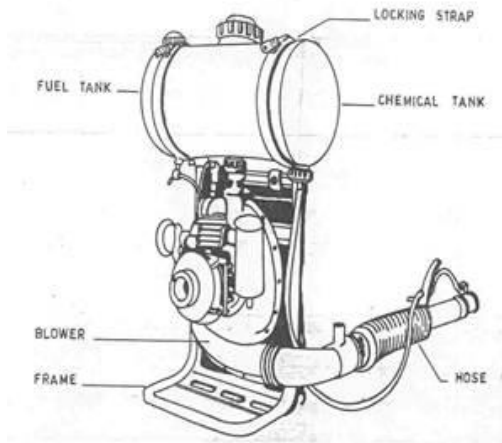

Motorized Knapsack sprayer



Motorized Knapsack sprayer



Motorized Knapsack sprayer spraying chemicals to wheat crop.

CONVERSION OF A MIST BLOWER IN TO A DUSTER

1. Replace the liquid delivery hose by a bigger diameter pleated hose to carry the powdery chemical from the tank into the air stream
2. Provide a air distributor at the bottom of the tank for stirring and keeping the chemical in suspended form



Motorized Knapsack duster

POWER SPRAYER

It is a heavy duty and efficient sprayer. It consists of a triplex pump with stainless steel piston with oil bath lubrication. It can Develops 250 to 350 pounds pressure and can deliver the solution up to 15 m.. It can be powered by a 3 HP engine or electric motor .It is convenient to spray with 4 to 6 spray lances at a time using the sprayer. There are sprayers can be operated by tractor PTO as well as by a power tiller..



Power sprayer

DUSTER

Duster is a machine used to apply chemicals in dust form. Dusters make use of air stream to carry pesticides in finely divided form on the plants. A duster essentially consists of

1. Hopper
2. Agitator
3. Feed control
4. fan or blower
5. Delivery nozzle

Types of dusters

1. Plunger type
2. Knapsack type
3. Rotary type
4. Power operated duster

1. **Plunger type** - it is a simple duster with a small piston. The piston drives a current of air over the dust in the hopper. The dust is carried away through a delivery spout. Small hand pump dusters of this type are available and are suitable only where the area to be dusted is small like vegetable gardens
2. **Knapsack type** - It is a duster with the powder container carried on the back of the operator. Knapsack dusters have a hopper through which a current of air is blown to pick up the dust. The air current is produced by a lever operated leather bellows. Shoulder straps are used to carry in the field. These dusters are suitable for small areas.
3. **Rotary duster** - Hand rotary dusters are useful to apply chemicals which are in powder form. It consists of a hopper, a fan, gear box, handle, delivery hose and a deflector plate. When the handle is rotated the fan rotates at high speed and draws air from outside. The chemical from hopper is fed in to the air stream in the suction side of the fan. The chemical mixes with the air, passes through the delivery line and is applied on the plants. The rate of delivery can be regulated. It is used to apply powdery chemicals to vegetables, sorghum etc. crops.



Hand rotary dusters

1. **Power operated duster**- Power operated duster mainly consists of a power driven fan, a hopper and a delivery spout. The fan creates strong air flow which causes the dust to blow off from the hopper to a considerable distance vertically or horizontally. Direction of dust is regulated by a movable spout suitably fitted with the unit. This type of dusters are used for large areas

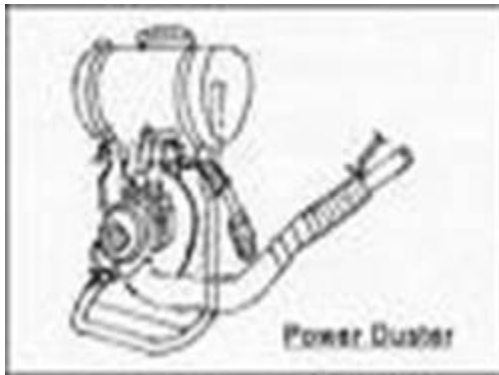

Power operated dusters

5. Aerial duster or crop duster - an aircraft is used for dusting or spraying large acreages with pesticides. Aerial spraying and dusting permit prompt coverage of large areas at the moment when application of pesticide is most effective and avoid the need for wheeled vehicles that might damage crops. The technique was greatly improved in the 1960s with the development of ultra-low-volume applicators, in which concentrated pesticides are distributed in amounts as small as 1 ounce per acre (70 grams per hectare).



Aerial dusting

Important terms

1. suction capacity of power sprayer- plunger type

$$Q = \frac{\pi}{4} \times D^2 \times L \times n \times 10^{-6}$$

Where

Q- theoretical suction capacity in lit/min

D- diameter of plunger, mm

n- rev/ min

L- stroke length, mm

B) Volumetric efficiency

$$= \frac{\text{Actual suction capacity}}{\text{Theoretical suction capacity}} \times 100$$

C) Pump efficiency

$$= \frac{\text{Water horse power}}{\text{Shaft horse power}} \times 100$$

Water horse power, kW

$$= \frac{Q \times 9.8 \times H}{60 \times 1000} \text{ kW}$$

MODEL QUESTIONS

1. State the functions of sprayer
2. Furnish the classifications of sprayers
3. List the advantages of sprayers
4. Mention the components and operation of hand sprayer
5. Mention the components and operation of power sprayer
6. Explain about different types of nozzles
7. Mention the components of rocker sprayer with a neat sketch and explain their Importance
8. When several nozzles are fitted in a pipe it is called as Spray gun True / False
9. In battery operated sprayers the component which breaks the chemical Solution in to fine particles is called
 a. spray gun b. nozzle c. spinning disc d. none
10. The chemical solution requirement of a sprayer is 80 lit/ha. The sprayer can be classified under
 a. high volume sprayer b. low volume sprayer
 c. ultra low volume sprayer d. none
11. Sprayers can be used to apply
 a. herbicide b. fungicide c. insecticide d. all the three chemicals
12. Which of the following components of a sprayer is very important?
 a. Spray gun b. Cut-off lever c. Nozzle d. Strainer
13. Cut off valve is fitted between pump and nozzle of a sprayer and is used to control the flow of chemical solution to the nozzle True / False
14. Explain the components and working of motorized knap sack Sprayers
15. State the advantages of knapsack motorized mist blower compared to hand sprayer
16. Explain the parts and working of battery operated sprayer

17. How will you convert a mist blower into a duster?
18. Differentiate compression sprayer and battery operated sprayer.
19. Calculate the water power which is required to discharge liquid @ 30 lit/ min at 30 kg/cm² pressure
20. In a pump, suction volume is 25 lit/ min and pump efficiency is 85%. Calculate the shaft power at a pressure of 35 kg/cm²



Lecture 12

HARVESTING TOOLS AND EQUIPMENT- SICKLES, PADDY REAPERS AND COMBINE - HARVESTING MACHINERY FOR GROUNDNUT, TUBER CROPS - SUGARCANE HARVESTERS

HARVESTING

The operation of cutting, picking, plucking digging or any combination of these for removing the whole crop or edible part of the crop from either under the ground or above the ground is called harvesting

Mechanical actions associate with harvesting are as follows:

1. Slicing action with a sharp tool.
2. Tearing action with a rough serrated edge
3. Scissoring action.
4. High velocity impact with sharp or dull edge tool.

ACCORDING TO POWER SOURCE USED HARVESTING TOOLS CAN BE CLASSIFIES AS

(1) Manually operated tools (ii) Animal drawn implements (iii) Power driven machines

SICKLE

Sickle is a simple manually operated harvesting tool. It is used for harvesting crops like paddy, ragi, sorghum etc. It essentially consists of a curved metallic blade and a wooden handle. Sickles are classified into two classes: (i) Plain and (ii) Serrated depending on the nature of the blade edge. In plain sickle the blade edge is smooth and sharp. In serrated sickle the blade edge is with sharp serrated teeth. The plain or serrated edge in the inner side of the blade is used for cutting the crop and hence called cutting edge The forged end of the blade used for fixing the handle is called tang.. Harvesting by sickle is a very slow and labour consuming device.

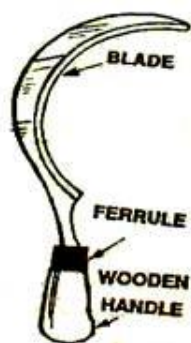

Sickle

MOWER

Mower is a machine to cut herbage crops and leave them in a swath. Animal drawn and tractor operated mowers are available

According to the cutting tool mowers are classified in to the following types such as: (i) Cylinder mower (ii) Reciprocating mower (iii) Horizontal rotary mower (iv) Gang mower and (v) Flail mower.

a) Cylinder mower: It has rotating helical blades arranged in cylindrical form. With the rotation of blades, forage or grasses are cut continuously. It is used for trimming grass in lawns, golf grounds etc.

b) Reciprocating mower: It is a mower with a knife made of several serrated triangular sections that reciprocate against stationary fingers. The knife cuts the crop by its reciprocating action. It is the most common type of mower used for harvesting forage crops and food grain crops like paddy and wheat. .

c) Horizontal rotary mower: It is a mower with high speed knife rotating in the horizontal plane. Due to rotation of knife, the grass and forage are cut uniformly. Used for trimming lawns , golf grounds etc.

d) Gang mower: It is an assembly of two or more ground driven cylinder mowers. It is used for trimming grass in lawns, golf grounds etc.

e) Flail mower: It is a mower with high speed swinging knives, operating either in the horizontal plane or in the vertical plane.. Used to cut herbaceous weeds like parthenium

CONVENTIONAL MOWER

The conventional mower mainly consists of: (i) A metallic frame (ii) Power transmitting unit and (iii) Cutting bar

Frame

The frame provides space for fitting gears, clutch, bearings, flywheel etc required for the operation of the harvester. A lever is used for lifting the cutting bar during road travel. . A flywheel is used to store energy from the engine to supply steady energy to the cutting mechanism for uniform cutting.

Power transmitting unit

It transmits the power from the power source either from the ground wheel in animal drawn mowers and from PTO for tractor drawn mowers to the cutting tool.

In bullock drawn mowers, the power transmitting unit consists of transport wheels, axle, gears, crank wheel, crankshaft and pitman. The transport wheel gives power to the axle from where the power is transmitted to crank wheel through the gears. From crank wheel the drive is transmitted to pitman through connecting rod. Crank wheel rotates in circular motion and

pitman makes reciprocating motion. Connecting rod converts rotary motion in to reciprocating motion. Knife is connected to pitman hence the knife reciprocates and performs the cutting job. There is a ball and socket arrangement to connect the knife with the pitman. The operator controls the driving unit with the help of a dog clutch.

In tractor drawn semi-mounted or mounted type mowers the cutter bar is operated by P.T.O. shaft of the tractor. A carden shaft transmits drive from PTO to the V pulley of the harvester. From V pulley, drive reaches the knife through gears, crank wheel, connecting rod and pitman. The knife reciprocates and cuts the crop. The cutting mechanism is driven independent of the forward motion of the tractor

Cutter bar

It is an assembly of several parts comprising of a knife, fingers, wearing plates, ledger plates, guides and shoes. The knife cuts the grass or grain crop by its reciprocating action. It is a metallic rectangular bar, on which triangular sections are mounted. The knife sections make reciprocating motion inside the fingers and cuts the plants. There are knife guides with clips to keep the knife sections very closely on the ledger plates for effective cutting action. The knife stops at the centre of the knife guard (finger) on each stroke which indicates good registration..

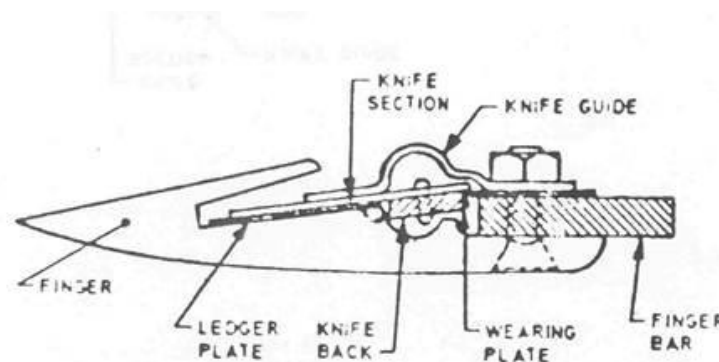

Cutter bar

Shoe - A shoe is always provided on each end of the cutter bar to regulate the height of cut and to provide easy and smooth sliding of the cutter bar on the land.

Ledger plate - It is a hardened metal inserted in a guard (finger) over which knife sections move to give a scissor like cutting action.

Wearing plate - It is a hardened steel plate attached to the finger bar to form a bearing surface for the back of the knife.

Knife - It is the reciprocating part of the cutter bar, comprising of knife head, knife back and knife sections.

Knife section - It is a steel plate of triangular shape with two cutting edges.

Knife head - It is the portion of the knife which is connected to the pitman.

Knife back - It is the strip of steel to which knife sections are riveted and the knife head is attached.

Grass board - Grass board is provided at the outer end of the mower which causes the cut plants to fall towards the cut material.

Pitman - Pitman is the link between the knife and crank wheel of the mower. It transmits motion to a knife. Wooden pitman is commonly used for the mowers which acts as safety device. It breaks and protects the cutter bar from damage when ever the knife is locked by some obstacle or choked by the crop.

Connecting rod - It is placed between pitman and crank wheel. It converts rotary motion of crank wheel in to reciprocating motion of the knife.

Breaking of knives - Breaking of knives is a common trouble in operation of a mower. It is caused due to play in bearings and worn out knife head holders. Non-alignment is an important cause for breaking the knife because when the mower is out of alignment, it works on a certain angle which is always harmful.

Alignment of mower

Under working condition, the standing crops exert pressure on the cutter bar tending to push it backward. In correct operating position, the crankpin, knife head and the outer end of the knife should be in a straight line. This line should be at right angle to the direction of travel of the mower. For achieving this object, the cutter bar is set at about 88° to the direction of motion i.e. inward lead of 2° is given to it in order to overcome the back pushing action of the crops. When the cutter bar is properly aligned, the knife and the pitman run in a straight line. This gives better cutting of the knife in the field. Generally 2cm lead per metre length of cutter bar is recommended.

Registration of mower

A mower knife is said to be in proper *registration* when the knife section stops in the centre of its guard (fingers) on every stroke i.e. the centre of the knife section is at the centre line of the guard, when it is in operating condition (Fig.3). Adjustment is commonly made by moving the entire cutter bar in or out with respect to the pitman. If mower is not well registered, there is unbalanced load, uneven cutting and excessive clogging of crops on the knife.

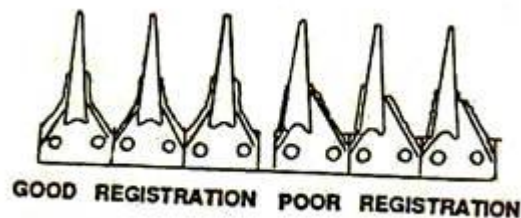

Registration of mower

SELF PROPELLED PADDY HARVESTER

It is suitable for harvesting non lodging varieties of paddy crop. The machine consists of an engine, gearbox, ground wheels, handle, and cutter bar assembly, star wheels and gathering header assembly. The power is taken from the engine pulley to the harvester main shaft through compound idlers. The crop is manually harvested along the four sides of the field for a width of 0.5m and cleared from the field for providing space to the machine. At one corner an area of 2.0 x 1.5m is manually harvested to place the machine initially in the field. Since the harvested crop is discharged at the right side of the reaper the machine has to be turned always to the left side. During forward motion of the harvester, crop enters in the cutter bar mechanism and gets sheared and the harvested crop is conveyed to right side of the machine by the conveyor belt. The harvested crop is windrowed in the field, collected manually and transported to threshing yard. The width of operation is 1.0 metre. The coverage is 1.5 ha/day

Advantages of using harvesters

1. Labour requirement is reduced
2. Large area can be harvested in shorter time. Saving in time
3. The availability of a harvest in a locality supports labour force to complete larger area. Hence timely harvest is possible.
4. Economical
5. Frees the land early for ploughing for the next crop

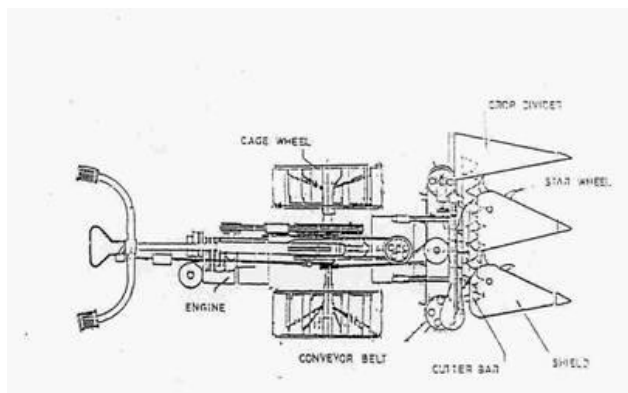

Paddy harvester



Paddy harvester

TERMS CONNECTED WITH HARVESTING OPERATION

Mower: It is a machine use to cut herbage crops and leave them in a swath.

Reaper: It is a machine to cut grain crops.

Reaper binder: It is a machine which cuts the crops and ties them into neat and uniform bundles.

Sickle: It is a curved steel blade with sharp edge in the inner side and a handle. It is used by human power. The person holds the tool and shears the straw or stalk and harvests the crop

Swath: The harvested material laid on the land by the machine when harvesting is in progress is called a swath.

Windrow: It is a row of material formed by combining two or more swaths.

Windrower: It is a machine to cut crops and deliver them in a uniform manner in a row.

COMBINE

It is a machine, which performs the functions of a reaper, thresher and winnower.

Functions

1. Cutting the standing crops
2. Feeding the cut crops with the threshing unit
3. Threshing the crops
4. Cleaning the grains freeing it from straw
5. Collecting the grains in a container

The functional components are

1. Header
2. Reel
3. Cutter bar
4. Elevator canvas
5. Feeder canvas
6. Feeding drum
7. Threshing drum
8. Concave,
9. Fan
10. chaffer sieve
11. Grain sieve
12. grain auger
13. Tailing auger
14. Grain elevator and
15. Grain container.

Header is used to cut and gather the crop and deliver it to the threshing cylinder. The straw is pushed back on the platform by the reel. Small combines use scoop type headers, while large combines use T type headers

Harvesting is done by a cutting unit, which uses the cutter bar similar to that of the mower.

The knife has got serrated edge to prevent the straw from slipping while in operation. There is a suitable cutting platform, which is provided with a reel and canvas.

The reel is made of wooden slates, which helps in feeding the crops to the cutting platform.

The reel gets the power through suitable gears and shafts. The reel revolves in front of the cutter bar while working in the field. The reel pushes the standing crops towards the cutting unit. The reels are adjustable up and down as in or out. The cutter bar of the combine operates like the cutter bar of a mower

The conveyor feeds the crop to the cylinder and concave unit.

The threshing takes place between the cylinder and concave unit of the combine. The basic components of the threshing unit of the combine are similar to a power thresher. As soon as the crops are threshed the threshed material move to straw racks. These racks keep on oscillating and separating the grains.

The cleaning unit consists of a number of sieves and a fan. The unthreshed grains pass through the tailing auger and go for re-threshing. The clean grain passes through the grain elevator

and finally goes to the packing unit. Grains are collected in a hopper provided at suitable place. The fan is adjusted such that the chaff etc., blown off the rear side of the machine. The size of the combine is indicated by width of cut it covers in the field.

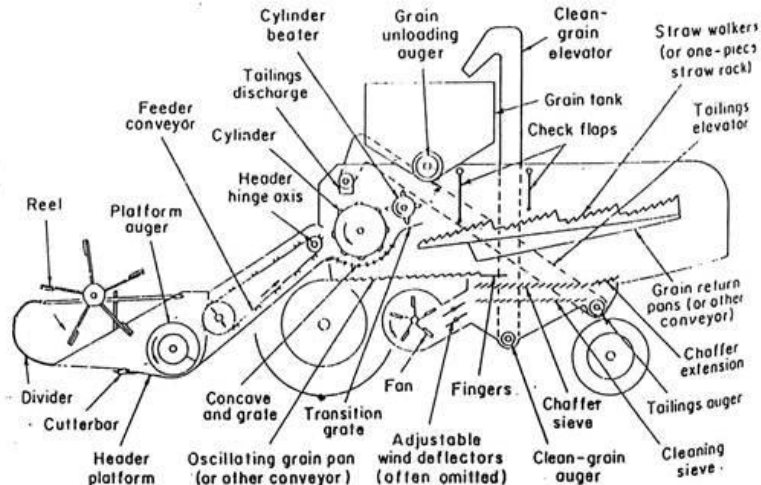

Fig. Schematic arrangement of the basic functional components of a typical self-propelled combine.



Paddy Harvester



Wheat Harvester



Straw Reaping in Wheat

Combine harvester

A combine may be self-propelled type and PTO driven type

Self propelled type

This has got its own dependent engine. This engine gives power for operating all the mechanisms as well as for pulling the weight of the combine. Size varies from 2-4 m.

PTO driven type

This combine is pulled by a tractor. The tractor pulls the combine by its tractive power. The power takes off shaft of the tractor supplies power to the cutting and threshing mechanisms.

The power requirement of the combine may be taken on 8 HP/m width of cut for pulled type machine and 12 HP/m width of cut for self propelled machines.

MODEL QUESTIONS

1. List the types of mowers
2. Mention the basic components a mower
3. Explain with a neat sketch the working of a cutter bar
4. List the types of harvesting methods
5. List the advantages of harvesters
6. Mention the components of paddy harvester with a neat sketch and explain their importance
7. Define registration and alignment
8. Differentiate plain and serrated sickle.
9. The machine which cuts the crops and ties them into a neat and uniform sheaves is known as
a. reaper binder b. mower c. harvester d. none
10. A mower knife is said to be in proper *registration* when the knife section stops in the centre of its guard on every stroke True/False
11. The material as left by the harvesting machine. Is called swath True/False
12. The machine used to cut herbage crops is called
a. reaper b. windrower c. mower d. harvester
13. Swinging knives are used in
a. cylindrical mower b. horizontal rotary mower c. flail mower d. reciprocating mower.
14. Mention the components of combine harvester with a neat sketch and explain their importance
15. Calculate total time required to harvest 2.5 ha of grass by means of a 2m mower being operated at 4 Km/h. Take field efficiency as 80%
16. How many hectares of land can be cut by a combine with 4 m cutter bar, when it is operating at 4km/h



Lecture 13

TOOLS FOR HORTICULTURAL CROPS - PROPAGATION TOOLS, PLANTERS AND HARVESTING TOOLS AND MACHINERY

PLANT PROPAGATION

Most plants reproduce more of their kind through production of seeds. This is sexual reproduction and it involves the exchange of genetic material between two parent plants. Many ornamental plants do not come "true" from seed. To increase the numbers of these plants, gardeners and horticulturists use asexual propagation. In asexual propagation, the new plants are genetically exact copies or clones of a single parent plant. The methods used in asexual propagation range from taking leaf cuttings of African violets to grafting apple cuttings onto root stocks. Fruit tree propagation is usually carried out through asexual reproduction by grafting or budding the desired variety onto a suitable rootstock.

GRAFTING is a method of asexual plant propagation widely used in agriculture and horticulture where the tissues of one plant are encouraged to fuse with those of another. It is most commonly used for the propagation of trees and shrubs grown commercially. (Grafting is limited to dicots and gymnosperms. Monocots lack the vascular cambium required). In most cases, one plant is selected for its roots, and this is called the **stock** or rootstock. The other plant is selected for its stems, leaves, flowers, or fruits and is called the **scion**. The scion contains the desired genes to be duplicated in future production by the stock/scion plant.

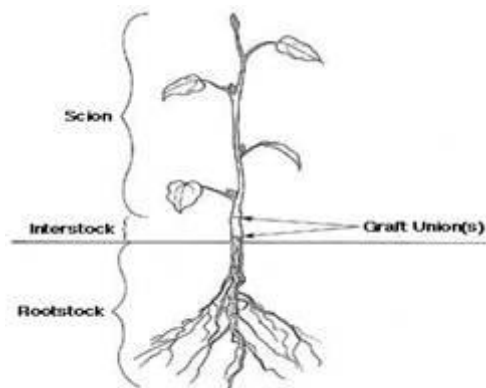

Figure 20. Double-worked graft.

In stem grafting, a common grafting method, a shoot of a selected, desired plant cultivar is grafted onto the stock of another type. In another common form called budding, a dormant side bud is grafted on the stem of another stock plant, and when it has fused successfully, it is encouraged to grow by cutting out the stem above the new bud.

BUDDING is a grafting technique in which a single bud from the desired scion is used rather than an entire scion containing many buds. Most budding is done just before or during the growing season. However some species may be budded during the winter while they are

dormant. Budding requires the same precautions as grafting. Be sure that the scion and rootstock are compatible, that the scion has mature buds, and that the cambia of the scion and rootstock match. Be especially careful to prevent drying or contamination of grafting materials.

TOOLS USED FOR BUDDING AND GRAFTING

1. Dibber
2. Budding and grafting knives-
3. Grafting Tools
4. Grafting Tape.
5. Pruning and Lopping Shears

DIBBER

Dibbers are used to make holes in seed bed to plant seeds, seedlings and bulbs. They are ergonomically designed consisting of a stainless steel sharp dibber and a hard wood handle joined together using a ferrule. The sharp dibber glides effortlessly into all soils. Overall length 27cm, weight 290g.



GRAFTING AND BUDDING KNIVES

Grafting and budding knives are designed specifically for these purposes and should not be used for carving and whittling wood. Using them for other purposes will make cutting edge blunt very quickly. . Grafting and budding knives must be kept razor sharp so they will cut smoothly. They are available in either left- or right-handed models. The blade is beveled on only one side, unlike conventional knives, which have blades that bevel on both sides down to the cutting edge

Grafting knife



Grafting knife



Grafting blade

Grafting blade - folding

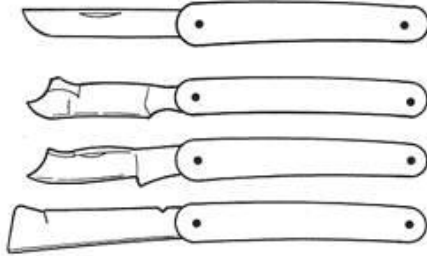

Budding knives



Budding knives

GRAFTING TOOLS

Grafting tool is designed for making the cleft graft. It is used when the rootstock's diameter is greater than 1 inch. The wedge-shaped blade is used to split the stock, and the flat pick opens the cleft so that the scions can be inserted. Once in place, the flat pick is removed and the cleft comes together to hold the scions in position.



Hand operated bench grafting tool- V shaped cut



Hand operated bench grafting tool - Chip and bud graft



Foot operated bench grafting tool- omega cut



Saw type electrically powered grafting machine



Omega type electricity operated grafting machine



Omega, V shaped and saw type machine cuts

PRUNING AND LOPPING SHEARS

Pruning and lopping shears are the scissors or sliding blade type rather than the blade and anvil type. They are used to harvest scion wood or bud sticks, As with knives, pruning and lopping shears should be kept razor sharp to give clean, close cuts

PRUNING SHEAR

Designed for those with smaller hands who may prefer a smaller, lighter pruner. It is comfortable to use yet every bit is as sturdy and powerful as other tools. Ideal for small pruning work such as grape vines, shrubs and young trees The anvil blade is screw mounted. The short blades facilitate closer cutting to the stem of the plant. Recommended Cutting Capacity up to 2 cm, length 18 cm and weight 200 gm



Pruning shear

FOLDING PRUNING SAW

It cuts branches up to 4 inches in diameter. Overall length 35 cm and blade length 15 cm. The shape of the blade is thinner at the top and thicker at the bottom - where the teeth are. This unique feature keeps only the teeth in contact with the material to be cut. This prevents clogging and binding, since the sides of the blade never come in contact with the wood.



Folding pruning saw

GRAFTING TAPE

Grafting tape is utilized as a cover/protecting bandage when using a splint for broken/cracked branches, twigs. It is also used to hold the soil and roots for the root over rock design of Bonsai styling. This product is 5/8" wide and 328 feet long, clear



TRANSPLANTERS (FOR HORTICULTURAL CROPS)

Need for transplanting

1. There are practical reasons for transplanting plants and flowers a) to coop up with season b) to coop up with time of release of water c) to raise healthy seedling in a controlled environment
2. Moving homes

3. Redesigning, Correcting, or Rearranging your garden
4. Relocating to a better spot in your yard (more sun or shade)
5. Avoiding roots from surrounding trees
6. Transferring potted plants and flowers to the garden
7. Alleviate crowding



Potato Planter

Relative difficulty in transplanting various vegetables

Easy to transplant	Medium difficulty	Difficult to transplant
Broccoli sprouts	Cauliflower	Watermelon
Brussels	Celery	Muskmelon
Cabbage	Egg plant	Squash
Tomato	Onion	Cucumber
Lettuce	Pepper	

Tools needed for manual transplanting of horticultural crops

1. Long bladed spade (sharp)
2. Sharp loppers
3. Small Trowel
4. Rose pruners
5. Bone Meal or other recommended fertilizer
6. Leather gloves
7. Wheelbarrow, wooden board, or plastic sheet to transport plant
8. Water (two large buckets for each plant)
9. Disinfecting sprays such as lime sulfur or fungicides

NURSERY STOCK VEGETABLE TRANSPLANTERS

The Mechanical Transplanters are excellent close spacing bed transplanters that work well in any soil condition. They can Plant at spacing as close as 5-8 cm in the row. Planters are available to plant 2-6 rows at a time with 15-20 cm row spacing. Float Wheel Direct Drive system provides positive plant spacing without wheel slippage. Twin hydraulic cylinders with equalizer permit even lifting of the planting mechanisms during field operation and transport. Optional double disc shoe cuts trash left in the beds.



Five row nursery stock vegetable transplanters



Four row nursery stock vegetable transplanters



Two row vegetable transplanter



Two row nursery transplanter



Two row nursery transplanter

TREE PLANTING

Tree planting is the process of transplanting tree seedlings generally for forestry, land reclamation, or landscaping purposes. A properly planted tree or shrub will be more tolerant of adverse conditions and require much less management than one planted incorrectly. Planting technique impacts water quality as it minimizes water, fertilizer and pesticide use. When making decisions on planting techniques, one should consider how the plant was grown in the nursery, the plant's drainage requirements, the soil type and drainage characteristics, and the availability of irrigation water. The plant should be specifically appropriate to the site, or the site should be amended to specifically fit the plant.

Planting depth

The most important consideration in planting trees and shrubs is the planting depth. Don't plant too deep. It is better to plant in a raised manner so the roots will not drown or suffocate. Dig planting holes 2 to 3 times wider than the root ball and the same depth. Locate the root ball on solid soil and not loose backfill. Wire baskets do not need to be completely removed from large field grown trees. Cut and fold down the top half of the basket, fold back the burlap, and remove nylon strings. Be sure to remove plastic liners or synthetic burlap type materials.

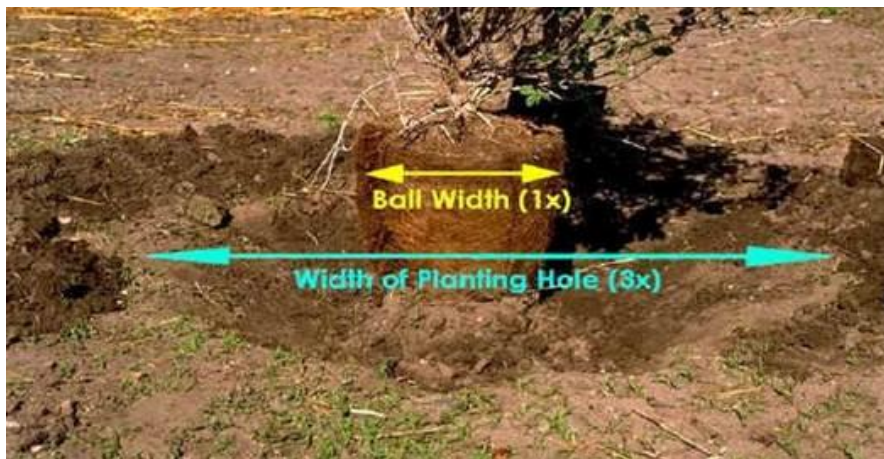

TRACTOR OPERATED POST HOLE DIGGER

Both mechanical and hydraulic drive post hole diggers are available to fit most landscaping , farming, or ranching applications. Auger drive mechanism may use either planetary drive or hydraulic drive. It consists of an auger, yoke tubing, gear box drive, power shaft, hitch frame etc. The digger is connected to tractor and moved to places where required. The drive to the gear box is obtained from PTO of the tractor. Holes of diameter 15 to 100 cm and depth 09 to 100 cm can be made by using appropriate augers.



Tractor operated Post hole digger- gear drive



Tractor operated Post hole digger- hydraulic drive

ENGINE OPERATED POST HOLE DIGGER (MANUAL HANDLING)

Two man auger is powered by a 4 cycle, 5 hp engine. The auger can make holes from 5 to 20 cm in diameter and depth up to 75 cm There is an optional 45 cm extension available. It is suitable for planting large shrubs, installing fences, building decks and digging mailbox holes.



Engine operated post hole digger - manual handling

HARVESTERS

FRUIT HARVESTER- MANUAL TYPE

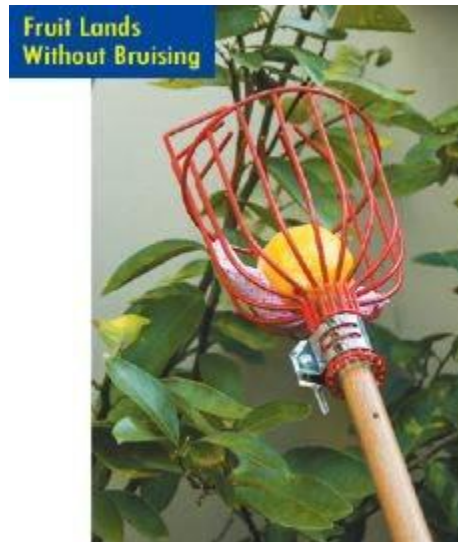

Using a fruit harvester is faster, easier and safer way to pick apples, oranges, peaches, plums and more from tree tops. Manually used fruit harvester consists of a PVC coated wire basket with finger like prongs that grasp the fruit. Padding is provided to the basket to protect fruit against bruising. The basket can be securely clamped to any length pole. The basket measures 31cm L x 15cm Diameter

Manual Fruit Harvester

CITRUS HARVESTER

Two types of mechanical harvesters are being used today for harvesting citrus

- a) Continuous canopy shake system
- b) Trunk shake system. Shake and catch system

Continuous canopy shake system is a self-propelled unit that shakes the tree canopy causing the fruit to fall from the tree and onto a catch frame. Trunk shake system simply shakes fruit to the ground, requiring the fruit to be picked up by a hand crew.

COMMON FEATURES FOR BOTH TYPES OF HARVESTERS

Whether self-propelled or tractor-drawn, the core unit of a continuous canopy mechanical harvesting unit consists of a series of whirls stacked horizontally. Each whirl consists of a series of approximately 6-foot-long, 1.5- to 2-inch-diameter rods mounted to the whirls, which are connected to a central drum. The rods are generally referred to as tines. The tines penetrate into the tree canopy, shaking the canopy horizontally to remove fruit.

The shake frequency of the tines can vary depending on the force needed to remove the fruit. On the OXBO MODEL, the operator of the shaker assembly can adjust the angle of the tine penetration to the angle of a hedged tree. The drum is mounted to the controlling unit so that

the interaction of the harvesting tines with the canopy begins at 3 feet from the soil surface. The drum, which contains the whirls, can be elevated up to 18 feet above the soil surface. During one pass, the drum can harvest up to 18 feet of canopy height. Hedged trees insure uniformity of tree shape and allow for maximum tine penetration into the tree canopy, thereby increasing fruit removal. To minimize fruit splitting from impact with the ground or catch frame, trees should be topped to a maximum of 16 to 18 feet.

CONTINUOUS CANOPY SHAKE SYSTEM



Citrus harvester- self-propelled system (Oxbo make)



Citrus harvester -self-propelled system (Korvan make)



Citrus harvester Tractor-drawn canopy shaker (Oxbo make)



Citrus harvester Tractor-drawn canopy shaker

SELF-PROPELLED HARVESTING UNITS- CITRUS HARVESTER

Self-propelled harvesting units work in pairs, one unit for each side of the tree. Each unit has leveling hydraulics, which allows it to work effectively in bedded groves. The paired units travel down the tree row at ground speeds that can vary from 0.5 to 1.3 miles per hour, thus allowing 200 to 400 trees per hour to be harvested. Each unit catches and separates the fruit

from leaves and stems, reducing the amount of trash delivered to the processing plant. Fruit can be conveyed directly to a goat-type truck, or up to 60 boxes can be temporarily stored on the OXBO harvester's deck to allow for continuous operation. The goat-type trucks are similar to a conventional harvesting goat but slightly larger with a capacity of between 130 and 150 boxes. These units transport the fruit to semi trailers, which deliver the fruit to the processing plants.

For maximum efficiency, the self-propelled shake and catch units are best suited for groves with uniform tree canopy size. Canopy uniformity can be facilitated by hedging and topping. Trunk alignment in the row, clear trunk height of 18 inches to the first branches, and long tree row length improve harvesting efficiency. Skirting height of 30 inches above the ground allows for the catch frame to easily travel under the tree canopy, minimizing lower limb damage and maximizing fruit recovery. Tree topping height should not exceed 16 to 18 feet and trees should have a canopy width from the tree trunk to the outer canopy of 6.5 to 8 feet. Some hand labor may be required to glean any fruit remaining in the tree or to retrieve fallen fruit that missed the catch frame. Under grove conditions outlined above, continuous shake and catch systems typically deliver 90 to 95% of the available fruit to the semi trailer. With gleaning crews, total fruit recovery approaches 98%. In cases where fruit prices are low, hand labor to glean fruit may not be economical.

A self-propelled continuous canopy shake and catch system uses a crew of six workers - 2 harvester operators and 4 goat drivers. Overall, harvest labor productivity improves from 5 to 10 times over a hand crew, depending on grove conditions and equipment downtime. For groves that lack tree size uniformity and have not been skirted, the tractor-drawn continuous canopy shaker provides an option with greater flexibility for the adoption of mechanical harvesting systems. This tractor-drawn system works in a similar fashion to the canopy shake and catch units but without the catch frame. Tines mounted in the whirl remove the fruit from the tree by a horizontal shaking action, allowing the fruit to fall to the ground. As with the self-propelled unit, the operator can adjust the tilt and elevation of the drum that contains the series of stacked whirls. Harvesting area is limited to the height of 18 feet. With an experienced operator and in trees less than 18 feet in height, 95% of the crop can be removed from the tree.

THE TRACTOR-DRAWN CANOPY SHAKE SYSTEM- CITRUS HARVESTER

The tractor-drawn canopy shake system must work in conjunction with a hand crew to gather fruit shaken off by the harvesting unit. The harvester can travel between one-half and one mile per hour and have the capacity to harvest between 100 and 200 trees per hour. The efficiency of this harvester is influenced by the size of the pickup crew. Typically, a harvester shakes only the number of trees that will provide the fruit that can be picked up within a day.

The pick up crew gathers fruit into 8- or 10-box tubs, which are then loaded into conventional high lift trucks or goats. Since hand crews glean most of the remaining tree fruit, the tractor-drawn canopy shaker system in conjunction with hand labor delivers up to 99% of the available crop. When the tractor-drawn canopy shaker is used, labor harvest efficiencies as compared to standard hand harvesting are improved by at least twofold.

As with the shake and catch systems, trees should be hedged with a canopy width from the

trunk of the tree to the outer skirt of no more than 8 feet. Trees should be topped to a height of no more than 18 feet. Multi-stemmed tree trunks or low hanging branches do not decrease harvesting efficiency as significantly as they do when the catch frame systems are utilized. Harvesting and roadside costs in the 2003-04 season for continuous canopy shake systems can range from \$1.00 to \$1.75 per weight box. The lower cost range reflects well-prepared, high-yielding trees that are harvested with a catch frame, and does not include the cost of a gleaning crew to collect non-harvested fruit. The cost per box of the tractor-drawn system typically is higher due to the additional labor requirements to gather the fruit from the ground. Actual harvesting costs will depend on specific grove conditions and gleaning requirements of the grower.

Higher-yielding blocks should enjoy a lower per-box cost of mechanical harvesting. Larger blocks or tracts in close proximity should command a lower price, since the harvesting equipment can work more efficiently for a longer sustained period of time. Whatever the price of a mechanical system, the relative comparison a grower needs to consider is the price a hand crew would charge to pick and roadside the same volume of fruit.

For the Florida citrus grower to remain competitive in a global environment, all options that reduce the harvesting costs must be considered. Mechanical harvesting for processed citrus fruit is a viable option to lower harvesting cost. Ongoing research conducted by the Florida Department of Citrus, the University of Florida, and private companies show that the above systems can reduce harvesting costs by 20 to 40 cents per box. Additionally, studies that have been conducted for multiple years have shown no adverse effects in tree health, productivity, or tree longevity where these systems have been used.

TRACTOR OPERATED TURMERIC HARVESTER

The unit consists of a blade with five bar points for easy penetration into the soil, a main frame and a hitch frame.. The blade is fixed at an inclination of 20° to a cultivator frame with straight tynes at both ends for easy penetration in to the soil. It can be hitched to the tractor at the hitch frame. For digging of turmeric, the blade with bar points penetrate into the soil, lift the turmeric rhizomes along with the soil and convey them to the lift rods which aids in separation of the rhizomes from the soil. The soil slip back to the ground and the dug out rhizomes deposited at the centre of the unit. The field capacity of the unit is 1.6 ha per day.

The salient features of the unit are:

- Results in 70 per cent saving in cost and 90 per cent in time when compared to manual digging.
- Extent of damage caused to the rhizomes is very much less (2.83 per cent)
- The un dug rhizomes left in the field is minimum (2.42 percent)



Turmeric harvester

POWER TILLER OPERATED POTATO DIGGER

Potato is being grown in the hilly regions. For harvesting potatoes, mechanization or improved implement has to be introduced to complete the harvest economically and in time. Because of ease of maneuverability of power tiller in hilly tracts, a potato digger attachment to power tiller is developed. The unit consists of a shank, a triangular shape ridger with a share and extension rods and a hitch frame. The share penetrates into the soil and the ridger bottom dig out potato along with the soil. When the harvested mass moves over the extension rods, the soil slips back to the ground and the partly cleaned potatoes deposit on the soil. The depth can be adjusted to set the depth up to 30 cm. The field capacity is 0.4 ha/day.

The salient features of the unit are:

- Digging with power tiller drawn potato digger results in 47.7 per cent of saving in cost and 68.0 per cent of saving in time when compared to manual digging



Lecture 14

EQUIPMENT FOR LAND DEVELOPMENT AND SOIL CONSERVATION - DOZERS, LEVELERS, CHISEL PLOUGH, SUB SOIL PLOUGH, BLADE HARROW, BUND FORMER LAND LEVELING

Ill effects of uneven land

1. The unevenness in land level is sometimes called surface topography. Within a field unevenness has a major effect on crop management and crop yields.
2. Unevenness in land level results in uneven water coverage. (Uneven water coverage means that more water is needed to wet up the soil for land preparation)
3. Unevenness in land level results in uneven crop stands, increased weeds and uneven maturing crops. (All of these factors result in reduced yields and reduced grain quality).

Benefits of Land leveling

1. Effective land leveling reduces the work in crop establishment and care, and increases yields.
2. Level land improves water coverage that reduces the amount of water required for land preparation, improves crop establishment and care
3. Decreases the time to complete field tasks
4. Reduces weed problems
5. Results in uniform crop maturity

Principles of land leveling

Leveling of land requires soil to be shifted from the high points of the field to the low points in the most cost-effective way.

PROCEDURE IN LAND LEVELING

- plough the field twice
- Measure the levelness of the field by conducting a topographic survey.
- draw a topographic map of the field
- mark the high and low areas in the field
- move soil from the high areas to the low areas in the most cost-effective manner
- repair levees

a) Plough the field

Plough from the center of the field outward in lands. If the field is wide it may be more efficient to plough a number of lands and cut out furrows in each field. Finish with a cut out furrow around the edge of the field beside the bund. This will help keep the bunds in good

shape, reduce the bund area and also act as drainage lines for the field most fields will need to be ploughed twice before leveling can commence

b) Mark the high and low spots in the field

Using either standing water in the field or height measurements from a topographic survey, mark the high and low areas in the field and form a strategy to most efficiently and effectively move soil from the high to low spots.

(Note: It is difficult to move soil more than 50 meters. If the soil has to be dragged more than 50 meters it may pay to first move soil from the middle of the field to the lowest places and then from the higher places to the middle of the field.)

c) Begin leveling

Position the leveling device in the high part of the field and drag soil to the lower part of the field.

(Note. If the fields are ploughed in lands and the same leveling procedure is adopted in the second year the field should end up relatively smooth and level.)

d) Maintain or repair levee (bunds)

Repair the levees either by first ploughing soil up against the levee or manually using a hoe or shovel. This is best done after leveling. Bulldozers can level fields. Levees can be manually repaired

(Note. Levees need to be maintained as any advantage of improved water management through leveling will be lost if water is able to escape through or over the levees.)

LAND LEVELING USING DRAFT ANIMALS

To level a field using a draft animal and a leveling board the following equipment are needed:

1. Animal or pair of animals (oxen, caribou)
2. Plough (moldboard)
3. Harrows or leveling board
4. Water source and Water pump (if fields are not flooded)

With water in the field, mark or note the high and low areas and form a strategy to most effectively move soil from the high to low spots. Weight will need to be added on to the harrow to move the soil. A ratio of 40kg weight/meter width of leveling board gives the best results.

LAND LEVELING USING A 4-WHEEL TRACTOR AND BACK BLADE

To level a field using a 4-wheel tractor and a back blade the following additional equipment are needed:

1. Plough (disc, moldboard or tine)
2. harrows (disc or tine)
3. Tractor blade or drag bucket
4. Surveying equipment

A field diagram should be drawn noting the level of cut and fill required in the field. With

water in the field, mark or note the high and low areas and form a strategy to most effectively move soil from the high to low spots. Tractor hydraulic system will be used to lower or lift the leveling blade.

LEVELING A LAND FOR A SMALL LAWN

1. Initial preparation of land for a lawn

Making a level lawn area is simple although does require some physical effort for the initial digging. Once the area has been dug over, the rest of the procedure is straightforward and easy.

It is wise to wait several weeks before seeding a newly graded area, especially if a lot of filling has been done, because the soil will settle and may form hollows. Any hollows that form must be filled and allowed to settle again or tramped down to ensure that the area is fairly level. To hasten the soil settling, give it a thorough and deep soaking with water.

2. Preparing Area for lawn

Mark out the area where you wish to plant a lawn with brightly colored paint in a spray can. Dig over the soil within that area to loosen it. Hammer flat-topped square-headed wooden stakes at each corner of the area and 10 to 15 cm apart in the ground in each direction. Level the stakes with a carpenter's level placed on a board which is long enough to reach three stakes. Each stake should protrude from the ground by 7.5 cm to 10 cm. Adjust the stakes as necessary to ensure that they are all level. Always work with the board over three stakes; left to right, right to left or diagonally. Do this until all the stakes have been made level. Add some rich soil to top dress that already in place after all stakes have been adjusted. This topsoil should be uniformly level with the tops of all stakes. Fertilize the area according to the seed producer's instructions. Scratch the surface area with a bamboo rake or a light lawn broom and your lawn area is ready to seed.

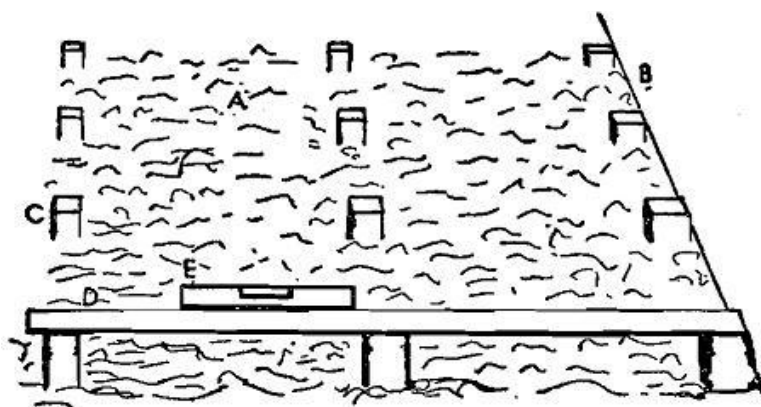

3. Seeding a lawn

Lay out a grid in the area to be seeded with strings stretched between tent pegs at the sides and the ends to form rectangles not more than 10' across. Place one or more planks on which to stand while sowing so as to avoid walking on the ground. Sow across each rectangle from side to side as an individual unit. Repeat the sowing from end to end. Rake the seed lightly into the

surface with a bamboo rake or a lawn broom. Roll or lightly tramp down the whole area to firm the seed in the soil. Keep the area well watered.

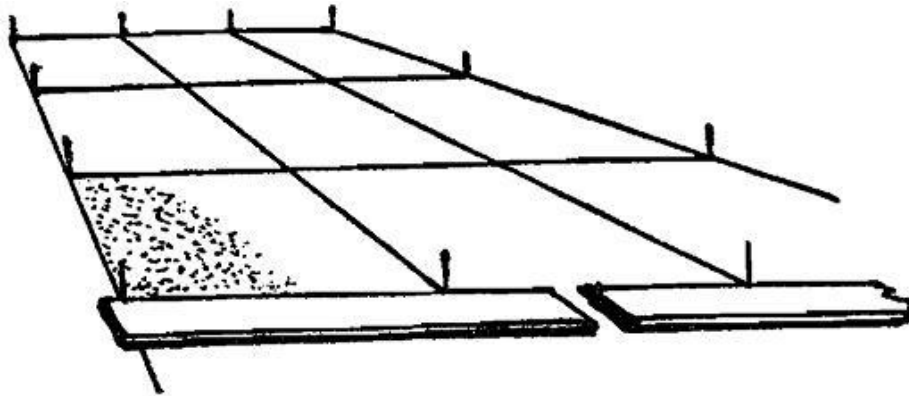

MACHINERY USED FOR LAND LEVELING

1. **Leveler** - tractor, power tiller and bullock drawn types are available. Heavy duty machinery. Meant for initial cutting and filling of land undulations
2. **Precision land leveler**- to provide desired grade either level or gently sloping. 8, 10, 12 13, 15 and 15 feet width of cut, 8 to 18 yards .Tractor HP 120 meant for farm use.
3. **Leveler with ripper attachment** - rippers loosen the soil prior to moving the soil.
4. **Scrapers** - tractor drawn animal drawn types available for smooth leveling. Used after Initial leveling is completed using a leveler.
5. **Scrap plane** - to create table top finish
6. **Drag scrapers** - Precision finish and final touch up. Suitable for small areas Weight boxes are used to add weight to increase depth of cut.
7. **Box scraper** - Box scrapers are used to smooth and level the ground. Rear Wheel makes he unit a mini land-plane. Skid shoes control depth of cut. Hitching adjustment for more or less cutting force to suit job.

LAND LEVELER- TRACTOR DRAWN

Land Leveler is used for leveling the land, filling the field depressions, back fillings the pits, farmyard clearing etc. It is also called as blade terracer. It consists of a leveling board, wings for soil retaining, angle adjusting screw and three point hitch frame. Soil retaining wings are fitted on both ends of the blade for carrying the soil without spillage. It is suitable for sticky and non-sticky soils as well. Levelers are available for tractors, power tillers and bullocks.



Tractor drawn land leveler



Agricultural Laser Land Leveling



Precision laser land levelers for farm use



Scraper for dirt movement with out laser control



A ripper attachment loosens the ground in the outer area so that field will settle uniformly and settle evenly

Scrap plane designed for use width lasers. It creates a smooth table top finish that no other machine can do.



Drag scrapers are used with laser control for precision finish, touch up and limited land leveling. They work well for short haul dirt moving and for smoothing.. Weight boxes are used to add weight for increased cutting.



Box scraper

CHISEL PLOUGH

The chisel plough is a common tool to get deep tillage (prepared land) with limited soil disruption. The main function of this plough is to loosen and aerate the soils while leaving crop residue at the top of the soil. This plough can be used to reduce the effects of compaction and to help break up plough pan and hardpan. Unlike many other ploughs the chisel will not invert or turn the soil. This characteristic has made it a useful addition to no-till and low-till farming practices which attempt to maximise the erosion-prevention benefits of keeping organic matter and farming residues present on the soil surface through the year.



A modern John Deere 8110 Farm Tractor using a chisel plough.

The chisel plough is typically set to run up to a depth of 300 to 400 mm. However some models may run much deeper. Each of the individual ploughs, or shanks, are typically set from 230 mm to 305 mm apart. Such a plough can encounter significant soil drag, consequently a tractor of sufficient power and good traction is required. When planning to plough with a chisel plough it is important to bear in mind that 10 to 15 horsepower (7 to 11 kW) per shank will be required.



Lecture 15

COST OF OPERATION OF FARM MACHINERY - PROBLEM SOLVING

Under cost analysis the cost incurred per hour of operation of a tool/ implement/ machine is calculated. This will give an idea of the payback period of the investment. This cost serves as the basis to fix up hire charges of the implement for custom hiring

Total cost of operation of an implement/ tool involves two costs namely 1. Fixed cost 2. Variable cost or operating cost.

Fixed cost - This cost relates to machine ownership. This cost can occur regardless of whether the machine is used or not. Fixed cost is inversely proportional to the annual use. It includes depreciation, interest on investment, taxes, insurance and housing costs.

Variable cost or operating cost - Those costs which are directly related to the amount of use are called variable costs. These costs are incurred only when the machine is used. Variable costs include repair and maintenance, fuel and lubricants, servicing and labour charges.

Calculation of fixed cost

1. **Depreciation** - It is the reduction in value of the machine with the passage of time. In the usual situation with field machines being operated only a few days in a year year, obsolescence is the most important factor affecting the depreciation (**Obsolescence** is the state of being which occurs when a person, object, or service is no longer wanted even though it may still be in good working order). A machine may become obsolete because of the development of improved models, changes in farm practices etc.
2. The following expression based on the straight line method is used to calculate the depreciation

$$D = ((C - S) / L) \times H$$

Where

D = Depreciation cost, Rs/hr

C = Initial cost of the machine, Rs

S = Salvage value of the machine, usually taken as 10 per cent of the initial investment of the machine Rs,

L = Expected life period of the machine, years

H = Number of working hours per year

Note: **Salvage value** is the estimated value of an asset at the end of its useful life.

ii. Interest on investment- Interest on investment in a farm machine is a legitimate cost, since money spent in buying a machine cannot be used for other productive enterprises. Annual charges of interest should be calculated on the basis of the actual rate of interest payable. The

rate of interest should reflect the prevailing rates (14%). The interest on investment is calculated by using formula given below.

$$I = (A \times i) / (100 \times H)$$

Where,
 I = Interest on investment, Rs/hr
 A = Average purchase price, Rs.
 H = Number of working hours per year
 i = Rate of interest (**usually it is assumed as 14 %**)

The **average purchase price** shall be calculated by the following expression. A

$$= (C + S) / 2$$

Where,

A = Average purchase price, Rs
 C = Initial cost of the machine, Rs.
 S = Salvage value of the machine, usually taken as 10 percent of the initial investment of the machine, Rs.

iii. Taxes, Insurance and housing - Sales tax and road tax can be distributed over the life of the machine. Farm machinery is sometimes insured against loss by theft or damage. Actual amount paid or to be paid annually for insurance and annual taxes if any should be charged. If the information is not available it may be calculated on the basis of 2 per cent of the average purchase price per annum. The charge for housing is taken as 1 per cent of the average purchase price of the machine.

So the charges for taxes, insurance and housing can be taken as 3 % per year of the average cost of the machine.

$$T, I \text{ and } H = 3 \times A / (100 \times H)$$

Where,

T, I and H = Taxes, insurance and housing charges, Rs/hr.
 A = Average purchase price, Rs.
 H = Number of working hours per year

The total fixed cost is the sum of depreciation (D), interest on investment (I) and Taxes, Insurance and housing (T, I and H) charges.

2. Variable cost

i. Repair and maintenance cost - Repair and maintenance costs are necessary to keep a machine in perfect working condition due to wear, part failure, renewal of tyre and tube and accidents. **The repair and maintenance costs shall be calculated as 10 per cent of the initial cost of the machine per year.**

$$R \ \& \ M = 10 \times C / (100 \times H)$$

Where,

R&M = Repair and maintenance costs, Rs/hr
 C = Initial cost of the machine, Rs.
 H = Number of working hours per year

ii. Fuel cost – Fuel consumption depends on the size of the power unit.
The cost of actual fuel consumption can be used in calculations

$$\text{Fuel cost (Rs/hr)} = \text{Quantity of fuel consumed per hour (Lit per hour)} \times \text{Cost of fuel (Rs/lit)}$$

iii. Lubricating oil cost - Cost of lubricating oil can be taken as 30 % of fuel cost

$$\text{Oil cost} = 30 / 100 \times \text{Quantity of fuel consumed per hour (Rs/hr)} \times \text{Cost of fuel (Rs/lit)} \quad (\text{Lit per hour})$$

iv. Operator cost - In performing custom work, the actual number of operators engaged for carrying out the operation should be used for calculation of operator charges. The prevailing rate of wages has to be adopted for calculation.

$$\text{Operator cost (Rs/hr)} = (\text{Number of persons engaged} \times \text{wages per Day}) / 8$$

The total variable cost is the sum of repair and maintenance cost (R &M), fuel cost, oil cost and operator charges.

Total cost of operation of the = Total fixed cost + Total machine per unit time,

Total cost of operation of the = Total cost of operation of the machine per unit area, Rs/ha machine per unit time, (Rs/hr)/ field capacity of the machine (ha/hr).

Class work

Problem : The initial cost of 35 hp Massey Ferguson Tractor owned by a farmer is Rs. 3,00,000/-. The tractor is expected to work for 10 years. In a year the farmer uses the tractor for 1000 hours. The farmer also owns a 11 tined cultivator. The tynes are spaced at 20 cm apart. The cost of the cultivator is Rs.12,000/-. The tractor consumes 3 liters of diesel while ploughing with the cultivator. The life of the cultivator is 10 years. The farmer uses the cultivator for 400 hours in a year. The cultivator is operated at a speed of 4 km/h. Calculate the cost of ploughing 2 ha of land with the cultivator. Assume all other necessary data.

Calculation

Cost of operation for tractor

1. Depreciation

$$D = ((C - S) / L) \times H \quad \text{Where}$$

$$D = \text{Depreciation cost, Rs/hr}$$

$$C = \text{Rs } 3,00,000$$

$$S = 10 \% \text{ of } C$$

$$L = 10 \text{ years}$$

$$H = 1000 \text{ hours per year}$$

$$D = (3,00,000 - 10/100 (3,00,000)) / 10 \times 1000$$

$$= \text{Rs. } 27 / \text{hour}$$

2. Interest I

Average cost A

$$A = (3,00,000 + 30,000)/2 = \text{Rs. } 1,65,000$$

$$I = (1,65,000 \times 14) / (100 \times 1000)$$

Rs. 23.1

3. Taxes, Insurance and housing

$$T, \text{ In and H} = 3 \times 1,65,000 / (100 \times 1000)$$

$$= \text{Rs. } 4.95$$

$$\text{Total fixed cost} = 27 + 23.1 + 4.95$$

$$= \text{Rs. } 55.05 / \text{h}$$

Variable cost

1. Repair and maintenance

$$R \ \& \ M = 10 \times 3,00,000 / (100 \times 1000)$$

$$= \text{Rs. } 30/\text{h}$$

2. Fuel cost F

$$= 3.0 \text{ lit/h} \times \text{Rs } 45/\text{lit}$$

$$= \text{Rs. } 135/\text{lit}$$

3. Lubricating oil cost

$$= (3.0/100) \times \text{Rs. } 135/\text{lit}$$

$$= \text{Rs. } 40.5 / \text{h}$$

4. Operator cost (Rs/hr)

$$= (1 \text{ person} \times \text{Rs. } 240/\text{day}) / 8$$

$$= \text{Rs. } 30 / \text{h}$$

$$\text{Total variable cost} = 30 + 135 + 40.5 + 30$$

$$= \text{Rs. } 235 / \text{h}$$

Cost of operation for tractor

$$\text{Total fixed cost} + \text{Total variable cost}$$

$$\text{Rs. } 55.05 + \text{Rs. } 235 = \text{Rs. } 290.05 / \text{h}$$

Cost of operation for implement

1. Depreciation

$$D = ((C - S) / L) \times H \text{ Where}$$

$$D = \text{Depreciation cost, Rs/hr}$$

$$C = \text{Rs } 12,000$$

$$S = 10 \% \text{ of } C$$

$$L = 10 \text{ years}$$

$$H = 400 \text{ hours per year}$$

$$D = ((12,000 - 10/100 (12,000)) / 10 \times 400)$$

$$= \text{Rs. } 2.7 / \text{hour}$$

2. Interest I

Average cost A

$$A = (12,000 + 1,200)/2$$

$$= \text{Rs. } 6,600$$

$$I = (6,600 \times 14) / (100 \times 400)$$

Rs. 2.31/h

3. Taxes, Insurance and housing

$$T, \text{ In and H} = 3 \times 6,600 / (100 \times 400)$$

= Rs. 0.495 /h

Total fixed cost = 2.7 + 2.31 + 0.495

= Rs.5.51 / h

Variable cost

1. Repair and maintenance

R & M = 10 x 12,000 / (100 X 400)

= Rs. 3 / h

Lubricating oil cost = Nil

Operator cost (Rs/hr) = Nil

Total variable cost = Rs. 3 / h

Cost of operation for implement

Total fixed cost + Total variable cost

Rs.5.51 + Rs.3 = Rs. 8.51

Cost of operation for tractor and implement

Rs. 290.05 / h + Rs. 8.51/h = Rs. 298.55/h

Field capacity of implement

FC =S W/10 ha/h

= (2.2 x 4.0) / 10 = 0.88 ha/h

Time required to complete 1.0 ha land

= 1/ field capacity

= 1/ 0.88

= 1.136 hour/ha

Cost of ploughing 1.0 ha land = No. of hours / ha x

cost of ploughing Rs./ ha

= 1.136 x Rs. 298.55

= **Rs. 339.16/ha**

Average Field Speeds, Field Efficiencies, and Effective Field Capacities Of some farm machinery:

Machine	Size	Speed (mph)	Field Efficiency (%)	Effective Field Capacity (A/h)
Fertilizer Spreader	40'	6	70	20.4
	50'	6	70	25.5
Manure Spreader	10'	5	63	3.8
Anhydrous Ammonia Applicator	9 knife	5	65	8.9
Plow	7-16"	5	85	4.8
Subsoiler	5-24"	5	85	5.2
Chisel Plow	11'3"	5.5	85	6.4
Offset Disk	12'	5.5	85	6.8
Tandem Disk	14'	6	83	8.5

Field Cultivator/Seedbed Conditioner	15'	7	85	10.8
Planter, seed only	6-30"	5	65	5.9
Grain or Soybean Drill	10'	6	70	5.1
Broadcast Seeder	20'	5	70	8.5
Sprayer	20'	6	65	9.5
Rotary Hoe				
Row-crop Cultivator	6-30"	4	80	5.8
Mower Conditioner rotary cutterbar	9'	7	83	6.3
Combine, soybeans*	12'	5	80	5.8
self-propelled Forage Harvester 3 rows	15'	3.8	73	5.0
				25

Problems

1. Calculate the cost of seeding one hectare of land with bullock drawn seed drill of size 5 x 22 cm. the speed of bullocks is 3 km/h. Hire charges of bullocks is Rs. 150/day.. Hire charges of seed drill is Rs. 100/day of 8 hours.
2. A fluted feed seed drill has 8 furrow openers of single disc type. The furrow openers are spaced 25 cm apart and the main drive wheel has a diameter of 120 cm. How many turns of main drive wheel would occur when the seed drill has covered 1.0 ha of land.



Lecture 16

TRACTOR AND IMPLEMENT SELECTION FOR DIFFERENT AGRICULTURAL OPERATIONS

Putting together an ideal machinery system is not easy. Equipment that works best one year may not work well the next because of changes in weather conditions or crop production practices. Improvements in design may make older equipment obsolete. And, the number of acres being farmed or the amount of labor available may change. Because many of these variables are unpredictable, the goal of the good machinery manager should be to have a system that is flexible enough to adapt to a range of weather and crop conditions while minimizing long-run costs and production risks.

POINTS TO BE CONSIDERED IN SELECTING FARM MACHINERY

To do better farm machinery selection, the following fundamental things must be understood

1. Machine Performance

Each piece of machinery must perform reliably under a variety of field conditions or it is a poor investment regardless of its cost. Tillage implements should prepare a satisfactory seedbed while conserving moisture, destroying early weed growth and minimizing erosion potential. Planters and seeders should provide consistent seed placement and population as well as properly apply pesticides and fertilizers. Harvesting equipment must harvest clean, undamaged grain while minimizing field losses. The performance of a machine often depends on the skill of the operator, or on weather and soil conditions. Nevertheless, differences among machines can be evaluated through field trials, research reports and personal experience.

2. Machinery Costs

Once a particular type of tillage, planting, weed control, or harvesting machine has been selected, the question of how to minimize machinery costs must be answered. Machinery that is too large for a particular farming situation will cause machinery ownership costs to be unnecessarily high over the long run; machinery that is too small may result in lower crop yields or reduced quality.

3. Ownership Costs

Machinery ownership costs include charges for depreciation, interest on investment, property taxes, insurance and machinery housing. These costs increase in direct proportion to machinery investment and size.

4. Operating Costs

Operating costs include fuel, lubricants and repairs. Operating costs per acre change very little as machinery size is increased or decreased. Using larger machinery consumes more fuel and lubricants per hour, but this is essentially offset by the fact that more acres are covered per hour. Much the same is true of repair costs. Thus, operating costs are of minor importance when deciding what size machinery is best suited to a certain farming operation

5. Labor Cost

As machinery capacity increases, the number of hours required to complete field operations over a given area naturally declines.

6. Estimating the Field Capacity of Farm Machines

If hourly or part-time hired labor operates machinery, it is appropriate to use the wage rate paid, plus the cost of any other benefits which may be provided, as the labor cost. If the farmer-owner or a hired worker who is paid a fixed wage operates machinery, then it is proper to value labor at its opportunity cost, or the estimated return it could earn if it were used elsewhere in the farm business, such as in livestock enterprises.

7. Timeliness Costs

In many cases, crop yields and quality are affected by the dates of planting and harvesting. This represents a “hidden” cost associated with farm machinery, but an important one nevertheless. The value of these yield losses is commonly referred to as “timeliness costs.”

8. Total Machinery Costs

Illustrates the effect that changes in machinery size have on each type of cost in a typical situation. For very small machinery (relative to crop acres), a slight increase in machinery size can lower timeliness and labor costs significantly, enough to more than offset the higher fixed costs. However, as machinery size continues to increase, the timeliness cost savings diminish, and eventually total costs begin to rise. One objective of machinery selection, then, is to select machinery in the size range where total machinery costs are lowest.

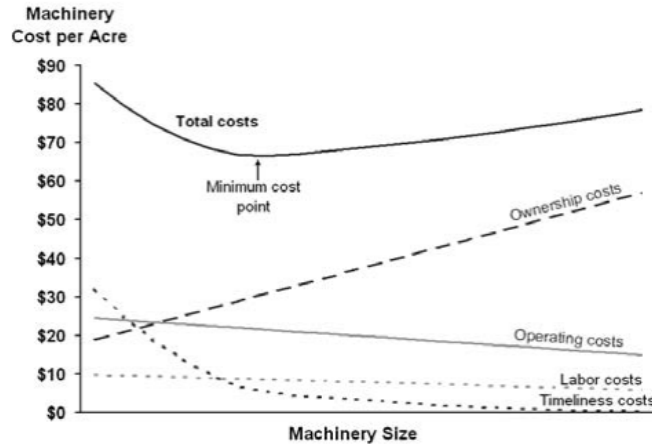

Fig1. Effect of increasing machinery size on machinery costs.

FACTORS THAT AFFECT THE SIZE OF MACHINERY NEEDED

Machinery recommendations must be based on the characteristics of each individual farm. The following factors influence machinery selection, and are discussed in order of importance.

1. Number of Crop Acres

As more crop acres are farmed, larger-scale machinery is needed to ensure that planting and harvesting are completed in a timely fashion. An alternative is to acquire a second unit of some machines, if an additional tractor and operator are available.

2. Labor Supply

The number of acres that can be completed each day is the most critical measure of machinery capacity, more than machine width or acres completed per hour. Increasing the labor supply by hiring extra operators or by working longer hours during critical periods may be a relatively inexpensive way of stretching machinery capacity. In addition, the cost of additional labor only needs to be incurred in those years in which it is actually used, while the cost of investing in larger machinery becomes “locked in” as soon as the investment is made. On the other hand, extra labor may not always be available when needed, and working long hours over several days can present a safety hazard.

3. Tillage Practices

The number of field days needed before planting is completed depends partly on the number of separate operations completed on each acre. Reducing the number of tillage practices performed or performing more than one practice in the same trip effectively decreases the amount of machinery capacity needed to complete field operations on time. Of course, machinery cost savings from reduced tillage must be compared to possible increased chemical costs and effects on yields.

Putting together an ideal machinery system is not easy. Equipment that works best one year may not work well the next because of changes in weather conditions or crop production practices. Improvements in design may make older equipment obsolete. And, the number of

acres being farmed or the amount of labor available may change. Because many of these variables are unpredictable, the goal of the good machinery manager should be to have a system that is flexible enough to adapt to a range of weather and crop conditions while minimizing long-run costs and production risks

POINTS TO BE CONSIDERED IN SELECTING A FARM MACHINERY

To do better farm machinery selection, the following fundamental things must be understood

1. Machine Performance

Each piece of machinery must perform reliably under a variety of field conditions or it is a poor investment regardless of its cost. Tillage implements should prepare a satisfactory seedbed while conserving moisture, destroying early weed growth and minimizing erosion potential. Planters and seeders should provide consistent seed placement and population as well as properly apply pesticides and fertilizers. Harvesting equipment must harvest clean, undamaged grain while minimizing field losses. The performance of a machine often depends on the skill of the operator, or on weather and soil conditions. Nevertheless, differences among machines can be evaluated through field trials, research reports and personal experience.

2. Machinery Costs

Once a particular type of tillage, planting, weed control, or harvesting machine has been selected, the question of how to minimize machinery costs must be answered. Machinery that is too large for a particular farming situation will cause machinery ownership costs to be unnecessarily high over the long run; machinery that is too small may result in lower crop yields or reduced quality.

3. Ownership Costs

Machinery ownership costs include charges for depreciation, interest on investment, property taxes, insurance and machinery housing. These costs increase in direct proportion to machinery investment and size.

4. Operating Costs

Operating costs include fuel, lubricants and repairs. Operating costs per acre change very little as machinery size is increased or decreased. Using larger machinery consumes more fuel and lubricants per hour, but this is essentially offset by the fact that more acres are covered per hour. Much the same is true of repair costs. Thus, operating costs are of minor importance when deciding what size machinery is best suited to a certain farming operation

5. Labor Cost

As machinery capacity increases, the number of hours required to complete field operations over a given area naturally declines.

6. Estimating the Field Capacity of Farm Machines

If hourly or part-time hired labor operates machinery, it is appropriate to use the wage rate paid, plus the cost of any other benefits which may be provided, as the labor cost. If the farmer-owner or a hired worker who is paid a fixed wage operates machinery, then it is proper to value labor at its opportunity cost, or the estimated return it could earn if it were used elsewhere in the farm business, such as in livestock enterprises.

7. Timeliness Costs

In many cases, crop yields and quality are affected by the dates of planting and harvesting. This represents a "hidden" cost associated with farm machinery, but an important one nevertheless. The value of these yield losses is commonly referred to as "timeliness costs."

8. Total Machinery Costs

Illustrates the effect that changes in machinery size have on each type of cost in a typical situation. For very small machinery (relative to crop acres), a slight increase in machinery size can lower timeliness and labor costs significantly, enough to more than offset the higher fixed costs. However, as machinery size continues to increase, the timeliness cost savings diminish, and eventually total costs begin to rise. One objective of machinery selection, then, is to select machinery in the size range where total machinery costs are lowest.

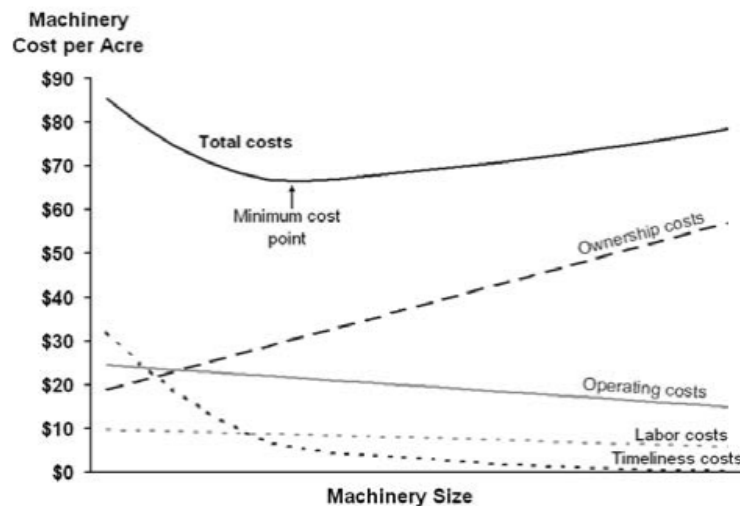

Fig1. Effect of increasing machinery size on machinery costs.

FACTORS THAT AFFECT THE SIZE OF MACHINERY NEEDED

Machinery recommendations must be based on the characteristics of each individual farm. The following factors influence machinery selection, and are discussed in order of importance.

1. Number of Crop Acres

As more crop acres are farmed, larger-scale machinery is needed to ensure that planting and harvesting are completed in a timely fashion. An alternative is to acquire a second unit of some machines, if an additional tractor and operator are available.

2. Labor Supply

The number of acres that can be completed each day is the most critical measure of machinery capacity, more than machine width or acres completed per hour. Increasing the labor supply by hiring extra operators or by working longer hours during critical periods may be a relatively inexpensive way of stretching machinery capacity. In addition, the cost of additional labor only needs to be incurred in those years in which it is actually used, while the cost of investing in larger machinery becomes “locked in” as soon as the investment is made. On the other hand, extra labor may not always be available when needed, and working long hours over several days can present a safety hazard.

3. Tillage Practices

The number of field days needed before planting is completed depends partly on the number of separate operations completed on each acre. Reducing the number of tillage practices performed or performing more than one practice in the same trip effectively decreases the amount of machinery capacity needed to complete field operations on time. Of course, machinery cost savings from reduced tillage must be compared to possible increased chemical costs and effects on yields.

ESTIMATING POWER REQUIREMENTS

Estimation of draft

In order to determine the draft requirement of an implement it is necessary to use a pull meter. Estimation of likely draft requirements can be taken from the table provided. However, these values will vary according to soil type, soil moisture, depth of working, ground speed and manufacturer.

Table 3 Estimating Draft Requirements

Implement	Draft per Unit Width (kN/m)
Chisel plough	4.5-5.5
Blade plough	4.0-4.5
Disc plough	5.0-6.0
Scarifier	4.0-4.5
Cultivator	3.0-3.5
Planter	2.5-3.5

A figure for total draft can be calculated by simply multiplying implement width by draft per unit width. Considering the example using the chisel plough, then:

$$\begin{aligned}
 \text{Total draft} &= \text{width (m)} \times \text{draft / metre (kN/m)} \\
 &= 7.8 \times 5 \\
 &= 39 \text{ kN (approx. 3900 kgf)}
 \end{aligned}$$

If a scarifier was used to replace the chisel plough, the draft per unit width would decrease to

4.5 kN/m and the resultant total draft would be 35 kN (3500 kgf). Remember this is draft or pull, not drawbar power.

Estimation of drawbar power

Drawbar power can be related to draft and speed, by using the formula below. Any one drawbar power level may be attained by a combination of pull and speed. That is, a large pull at a low speed could produce the same drawbar power as a small pull at high speed.

$$\text{Drawbar power} = \frac{\text{pull (kN)} \times \text{speed* (km/hr)}}{3.6 \text{ (constant)}}$$

Using the same chisel plough as in the previous example, the power requirements become:

$$\begin{aligned} \text{Drawbar power} &= \frac{39 \times 8}{3.6} \\ &= 87 \text{ kW (116hp)}. \end{aligned}$$

*Speed has been determined by the initial assumption when working out the required implement width.

Note: Kilowatts (kW) x 1.34 = Horsepower (hp)

Horsepower (hp) x 0.746 = Kilowatts (kW)

At this point, it would pay to work through all of the tillage operations and determine the requirements for each, after closely considering the time available and field efficiency. The largest power requirement would be then used in determining engine power.

Estimating engine power

Once drawbar power has been calculated, a decision needs to be made about what type of tractor is to be used.

The selection decision between wheels or tracks is far too complex a topic to be covered in this chapter. Suffice to say that if set-up and matched correctly, the operating costs should be similar for either tractive type. The decision between two wheel drive and four wheel drive is much simpler as it is determined by the minimum available size of a 4WD and the maximum size of a 2WD (that is approximately 150 kW or 200 hp).

From Table 2, it is now possible to determine the size of tractor required. In using the comparative chart it would be unwise to determine engine size using the maximum power figure as conditions vary both from season to season and even within any one season. Having a little extra capacity is also a safeguard against overloading. A more realistic figure is the normal operation level.

Table 4: Tractor Crankshaft Power (Chisel plough example)

Tractor	Drawbar HP/ Efficiency	Crankshaft Power (kW)
2WD	(87 x 100)/ 40	=217 kW (290 hp)
FWA	(87 x 100)/ 45	=193 kW (259 hp)
4WD	(87 x 100)/ 50)	=174 kW (232 hp)
Tracklayer	87 x 100)/ 65	=134 kW (178 hp)

CONCLUSION

If a step by step approach is used when matching power units and implements, it is possible to eliminate the majority of guess work that is normally employed when a machinery purchase decision is made.

This approach is simplistic but does allow changes to any of the inputs. Care must be taken not to overestimate either the time available to complete the task or field efficiency.

APPENDIX

Table 1 shows estimated draft requirements for various implements

Table 1 . Default Values for Speed, Field Efficiency, and Draft Requirements.

Equipment Name	Speed (mph)	Draft (lb. per unit of width)	Average Range
Tillage			
Moldboard plow (16 in. bottom, 7 in. deep)			
Light soil	5.0	320	220 - 430 per foot
Medium soil	4.5	500	350 - 650 per foot
Heavy soil	4.5	800	580 - 1,140 per foot
Clay soil	4.0	1200	1,000 - 1,400 per foot
Chisel-plow (7-9 in. deep)	5.0	500	200 - 800 per shank
Disk			
Single gang			
Tandem	5.5	75	50 - 100 per foot
Heavy or offset	5.5	200	100 - 300 per foot
	5.0	325	250 - 400 per foot
Field cultivator	5.0	300	200 - 400 per foot
Spring-tooth harrow	5.0	200	70 - 300 per foot
Spike-tooth harrow	6.0	50	20 - 60 per foot
Roller or packer	5.0	100	20 - 150 per foot
Cultivator			
Field (3-5 in. deep)			
Row crop	5.0	250	60 - 300 per foot
	4.5	80	40 - 120 per foot
Rotary hoe	7.5	84	30 - 100 per foot
Subsoiler (16 in. deep)			
Light soil			
Medium soil	4.5	1500	1,100 - 1,800 per foot
Heavy soil	4.5	2000	1,600 - 2,600 per foot

	4.5	2600	2,000 - 3,000 per
Planting			
Planter only	5.0	150	100 - 180 per row
Planter with attachments	5.0	350	250 - 400 per row
Grain drill			
No-till drill	5.0	5.0	30 - 100 per foot
	5.0	200	160 - 240 per foot
Applying Chemicals	4.5	425	375 - 450 per
Anhydrous ammonia applic.			shank

This Book Download From e-course of ICAR
VISIT FOR OTHER AGRICULTURE BOOKS, NEWS,
RECRUITMENT, INFORMATION, AND EVENTS AT
WWW.AGRIMOON.COM

Give FeedBack & Suggestion at info@agrimoon.com

DISCLAIMER:

The information on this website does not warrant or assume any legal liability or responsibility for the accuracy, completeness or usefulness of the courseware contents.

The contents are provided free for noncommercial purpose such as teaching, training, research, extension and self learning.

***** 😊 *****